

Ersatzteile Spare parts

Version 1.0.6

Drehmaschine

Lathe

<input type="radio"/>	OPTI <u>turn</u> [®] TU 2506	3425001 3425003
<input type="radio"/>	OPTI <u>turn</u> [®] TU 2506V	3425006
<input type="radio"/>	OPTI <u>turn</u> [®] TU 2807	3427001 3427003
<input type="radio"/>	OPTI <u>turn</u> [®] TU 2807V	3427006

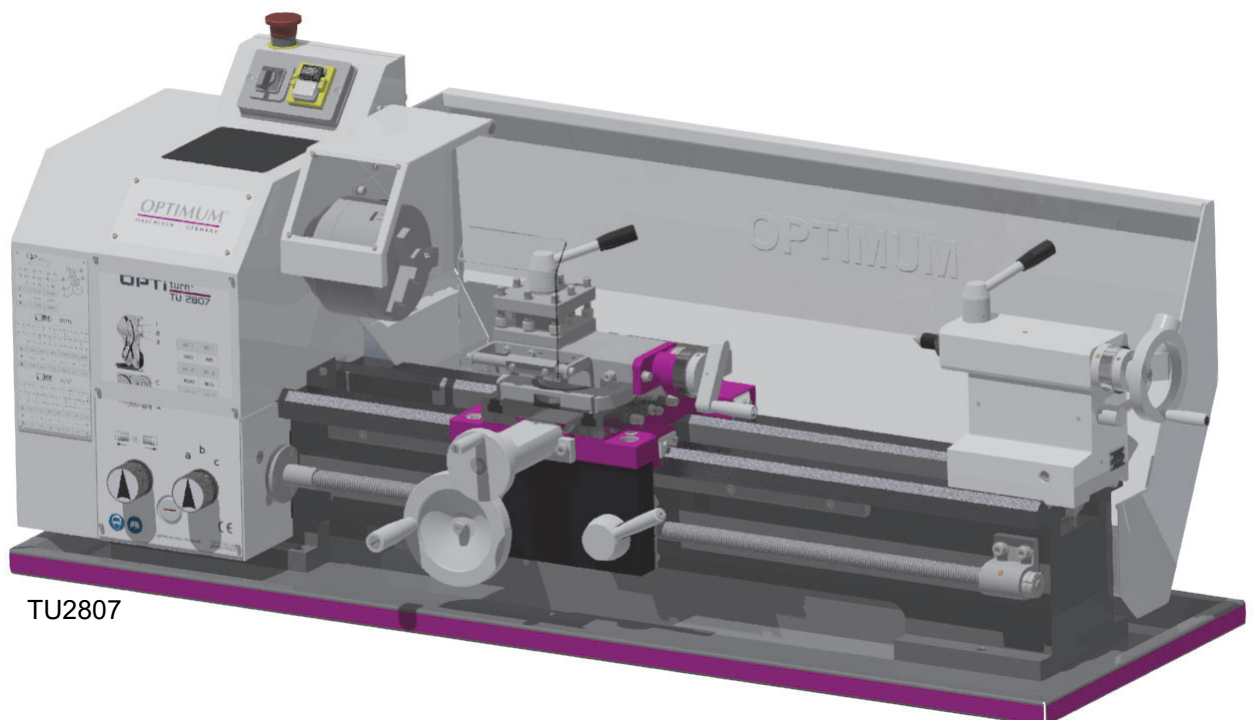

TU2807

1 Ersatzteile - Spare parts

1.1 Ersatzteilbestellung - Ordering spare parts

Bitte geben Sie folgendes an - *Please indicate the following* :

- Seriennummer - *Serial No.*
- Maschinenbezeichnung - *Machines name*
- Herstellungsdatum - *Date of manufacture*
- Artikelnummer - *Article no.*

Die Artikelnummer befindet sich in der Ersatzteilliste. *The article no. is located in the spare parts list.* Die Seriennummer befindet sich am Typschild. *The serial no. is on the rating plate.*

1.2 Hotline Ersatzteile - Spare parts Hotline



+49 (0) 951-96555 -118

ersatzteile@stuermer-maschinen.de



1.3 Service Hotline



+49 (0) 951-96555 -100

service@stuermer-maschinen.de



1.4 Ersatzteilzeichnungen - Spare part drawings - TU2506 | TU2506V

A Oberschlitten - Top slide



Abb. 1-1: Oberschlitten - Top slide TU 2506

TU2506_TU2506V_parts.fm

C Bettschlitten - Bed slide

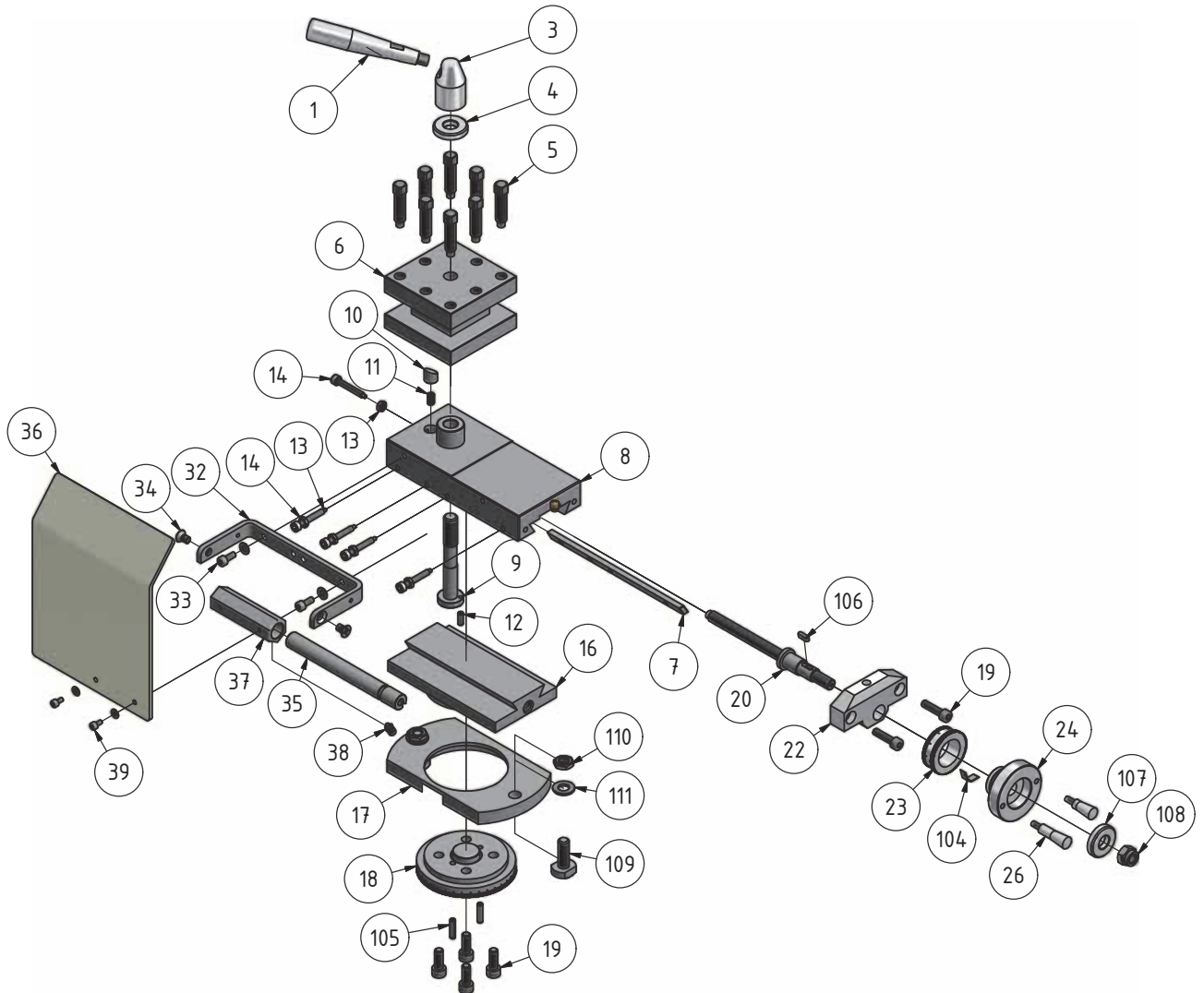

Abb. 1-3: Bettschlitten - Bed slide TU 2506

TU2506_TU2506V_parts.fm

D Ersatzteilzeichnung Reitstock - Tailstock

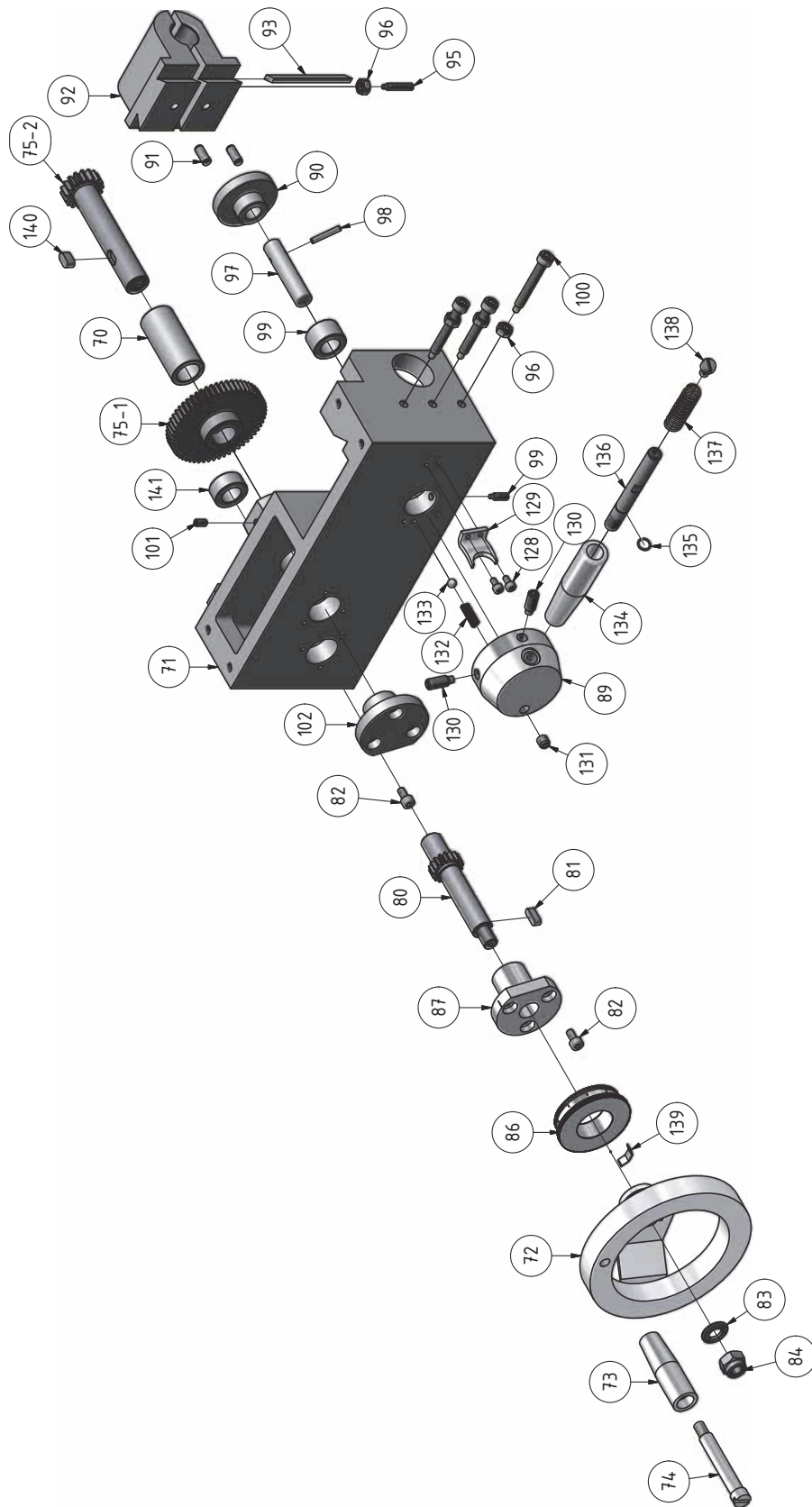

Abb. 1-4: Reitstock - Tailstock TU 2506

E Maschinenbett - Machine bed

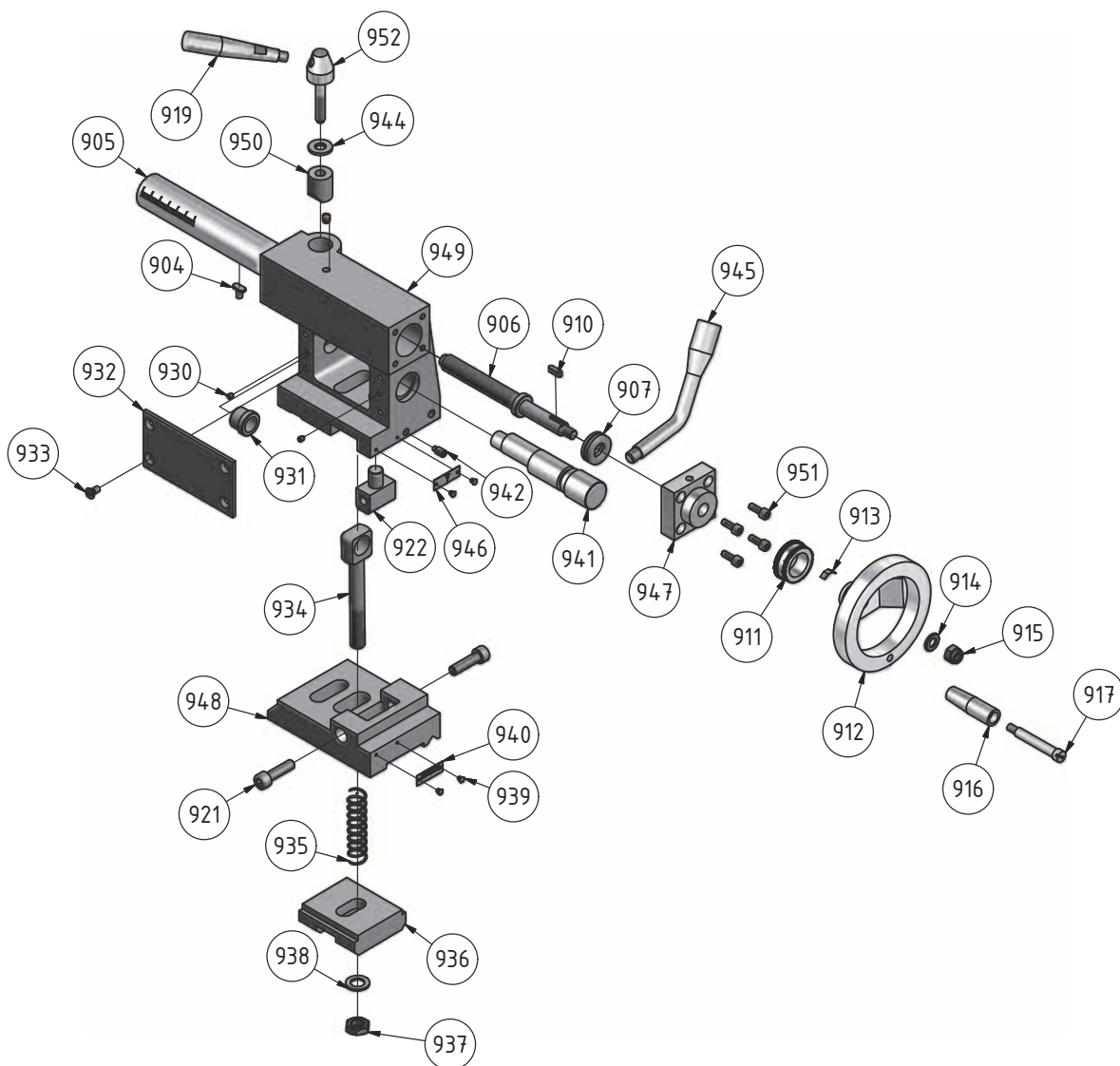

Abb. 1-5: Maschinenbett - Machine bed TU 2506

F Vorschubgetriebe 1 von 2 - Feed gear 1 of 2

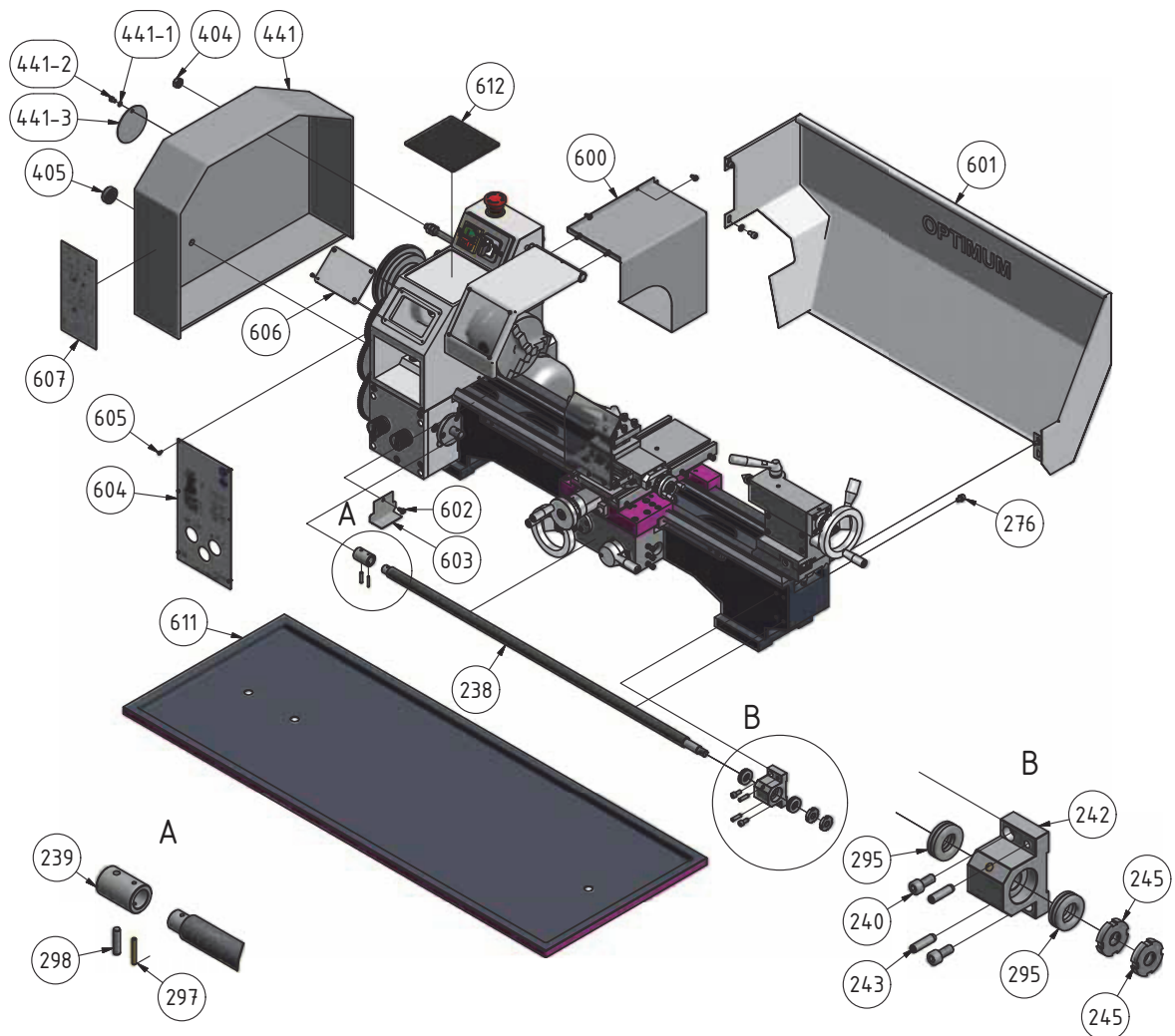

Abb. 1-6: Vorschubgetriebe 1 von 2 - Feed gear 1 of 2 - TU 2506

G Vorschubgetriebe 2 von 2 - Feed gear 2 of 2

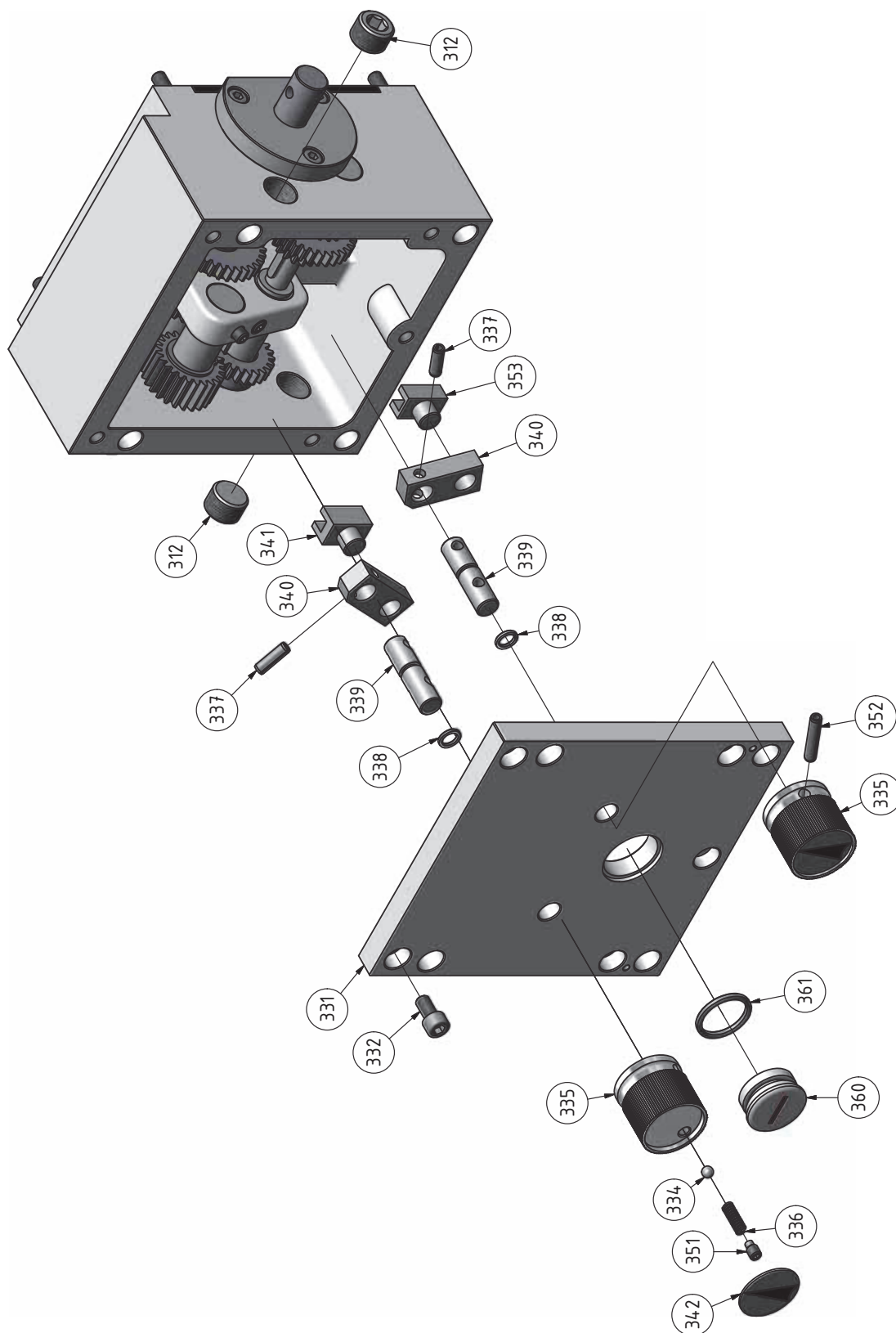

Abb. 1-7: Vorschubgetriebe 2 von 2 - Feed gear 2 of 2 - TU2506

TU2506_TU2506V_parts.fm

I Spindelstock 2 von 2 - Headstock 2 of 2

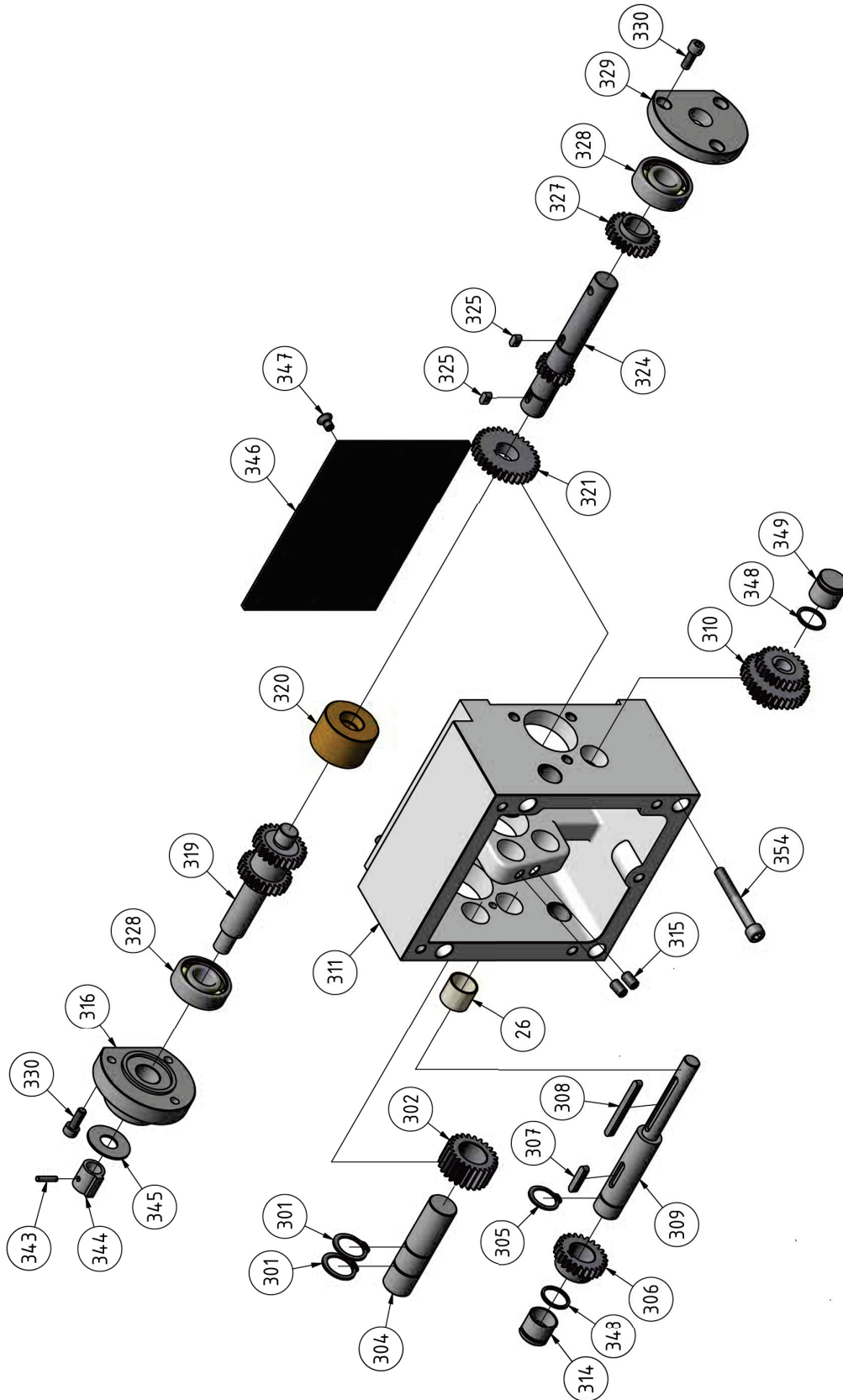

Abb. 1-9: Spindelstock - Headstock 2 of 2 - TU2506

J Spindelstock - Headstock TU 2506 V

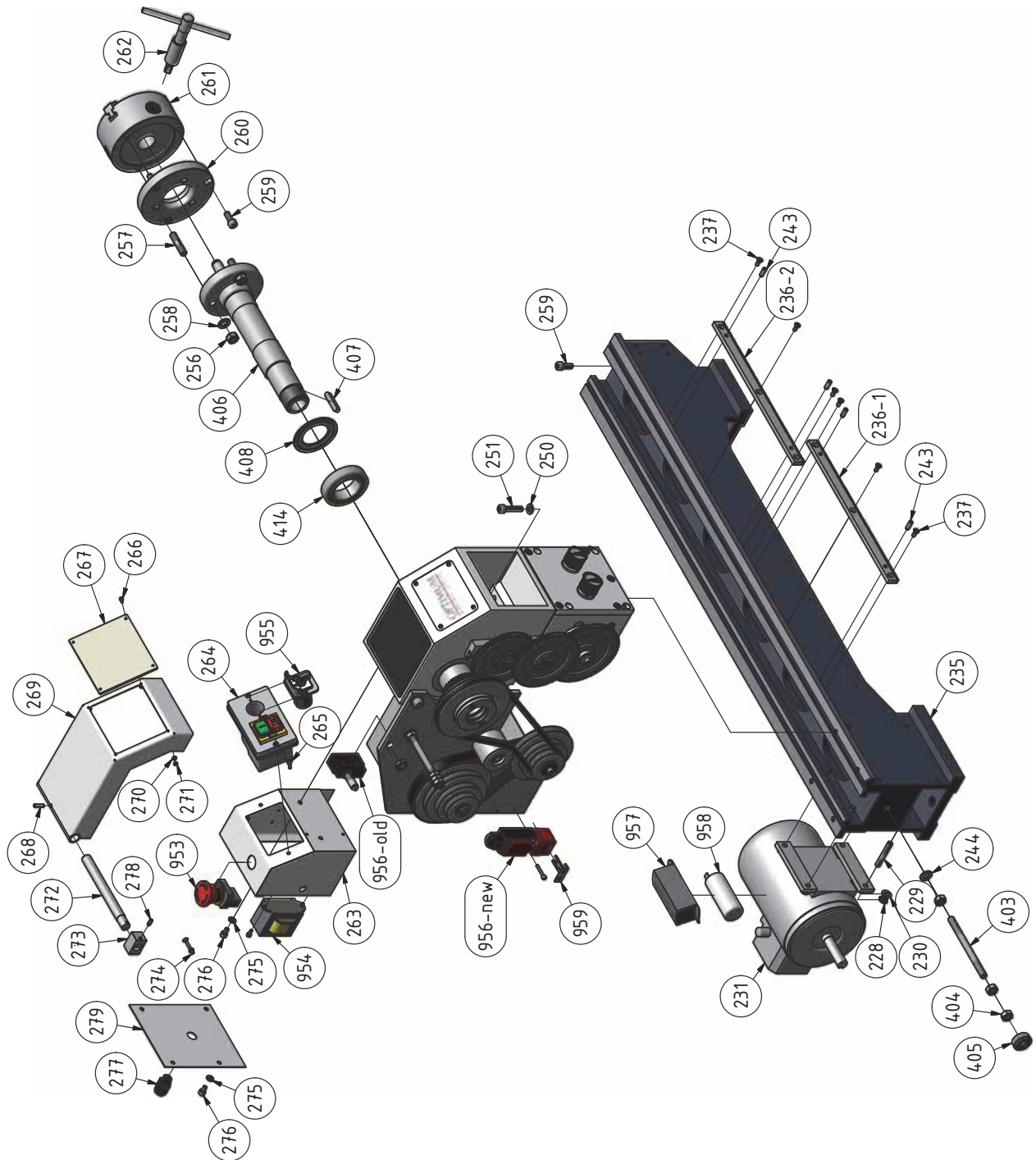

Abb. 1-10: Spindelstock - Headstock TU 2506 V

TU2506_TU2506V_parts.fm

nur TU2506V - Ersatzteilliste - Spare parts list - TU2506V only					
Pos.	Bezeichnung	Description	Menge Qty.	Grösse Size	Artikelnummer Item no.
1	Riemenscheibe	Belt pulley	1		0342500601
2	Zahnriemen	Timing belt	1	230XL 070	0395350
3	Welle	Shaft	1		0342500603
4	Nutmutter	Slotted nut	1		0342500604
5	Endschalter Riemenabdeckung	Cover limit switch	1	bis/to 2015	0460015
5-new	Endschalter Riemenabdeckung	Cover limit switch	1	ab/from 2015 / QKS-8	0329035017
6	Grundplatte	Base plate	1		0342500606
7	Riemenscheibe	Belt pulley	1		
8	Bundscheibe	Flanged washer	1		
9	Antriebsrad	Drive gear	1		
10	Bundscheibe	Flanged washer	1		
11	Innensechskantschraube	Socket head screw	4	GB 70-85/M8x20	
12	Motor	Motor	1		03020245189
13	Passfeder	Fitting key	1	DIN 6885/A6x6x45	
14	Riemenscheibe	Belt pulley	1		0342500614
15	Abdeckung	Cover	1		
16	Buchse	Bushing	1		
17	Drehzahlsensor	Rotation speed sensor	1		
18	Keilriemen	V-belt	1	7Mx775	
19	Innensechskantschraube	Socket head screw	2	GB 70-85/M4x20	
20	Halterung	Bracket	1		
21	Brushlesscontroller	Brushlesscontroller	1		0302BCV3L
22	Endschalter Drehfutterschutz	Lathe chuck cover switch	1		0460015
23	Hauptschalter	Main switch	1		
24	Drehfutterschutz	Lathe chuck cover	1		03425001269
26	Potentiometer	Potentiometer	1		
27	Drehzahlanzeige	Rotation speed display	1		03020245167
28	Ein-Aus-Taster	On-off button	1		
29	Rechts-Links-Schalter	Change-over switch	1		0460009
30	Not-Aus-Taster	Emergency stop button	1		
31	Betätiger	Switch actuator	1		0460054

K Wechselradgetriebe - Change gear

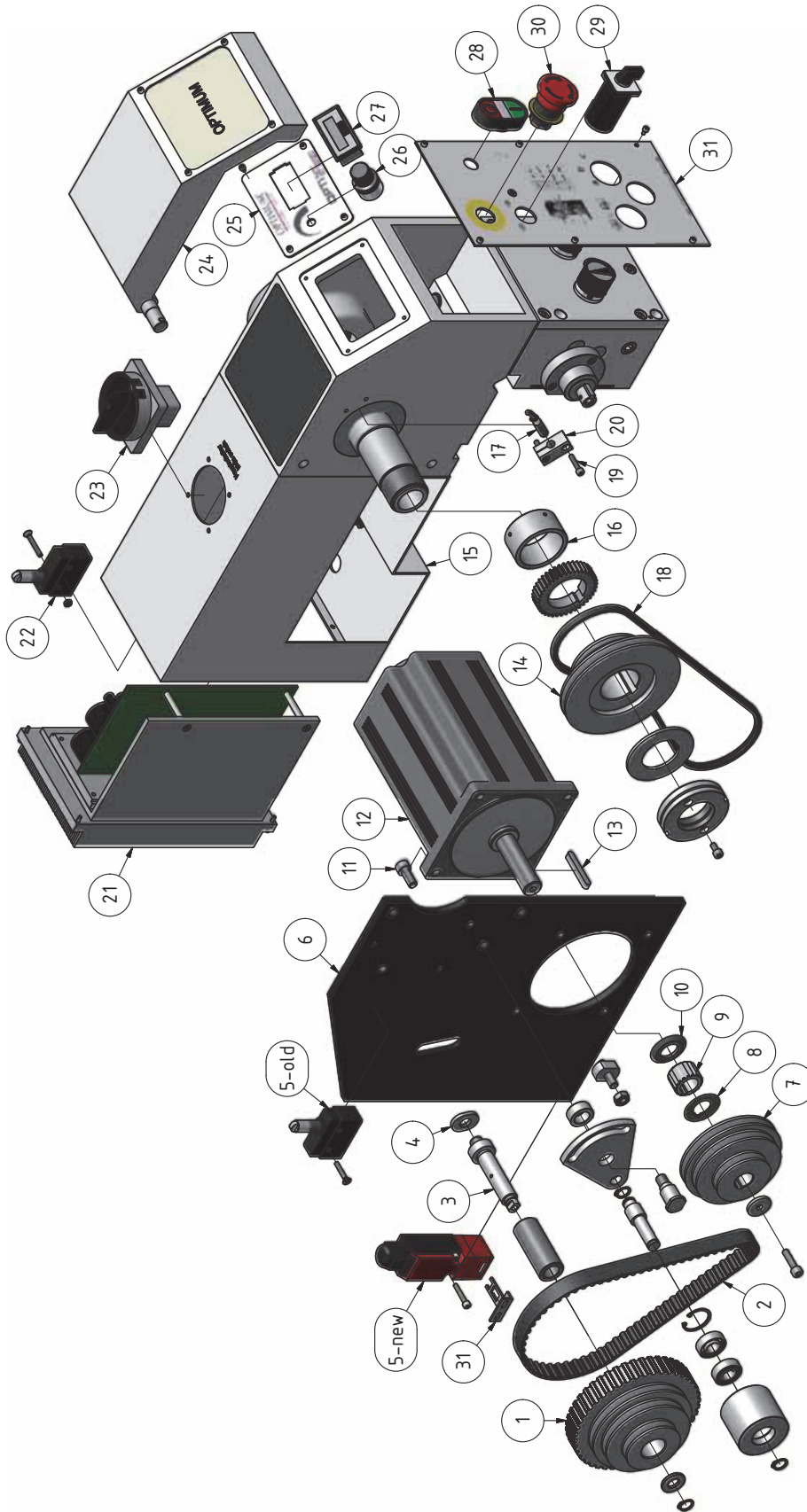

Abb. 1-11: Wechselradgetriebe - Change gear

L Maschinenschilder - Machine labels TU 2506

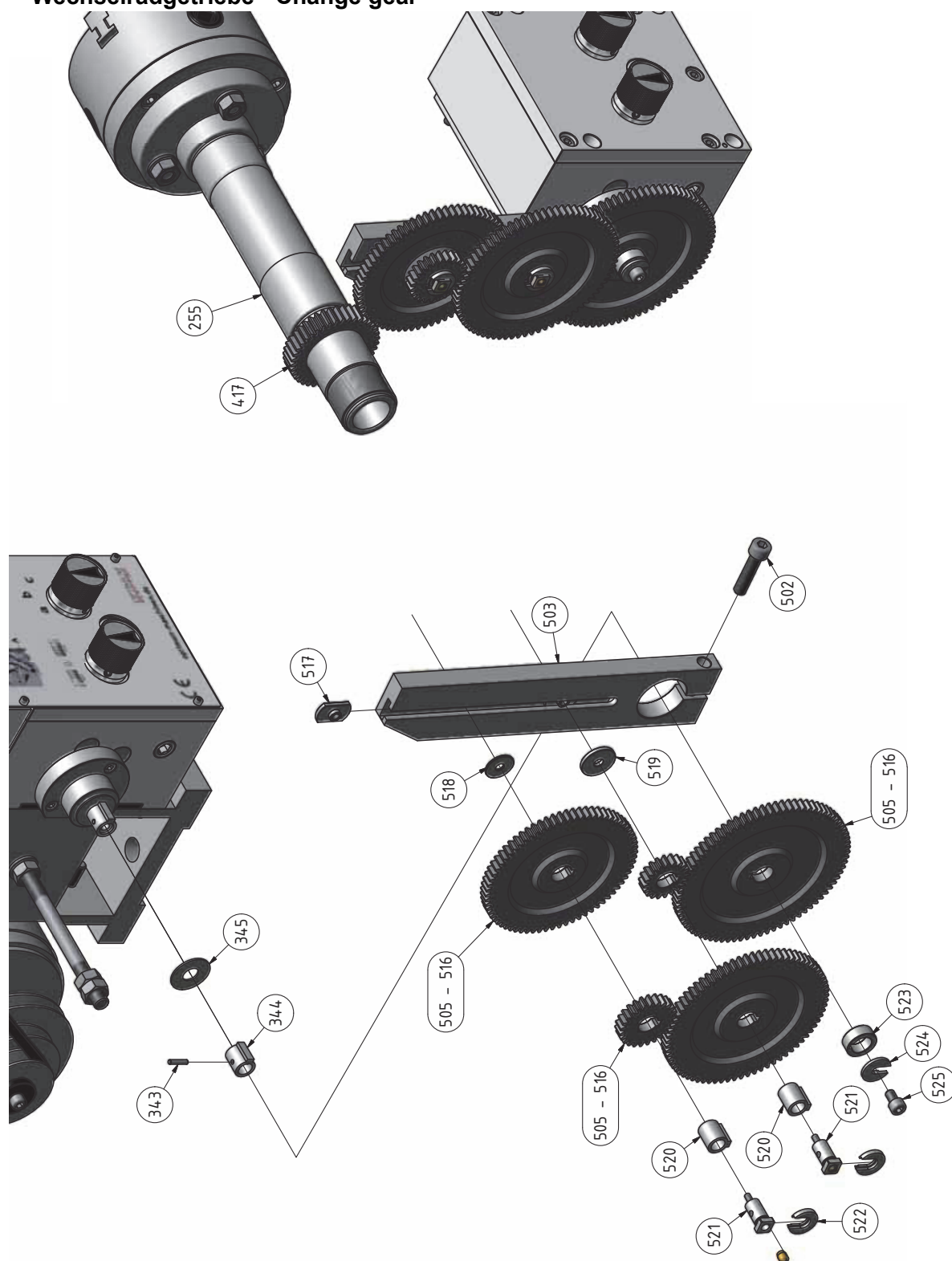

Abb. 1-12: Maschinenschilder - Machine labels

Maschinenschilder - Machine labels TU2506					
Pos.	Bezeichnung	Description	Menge Qty.	Grösse Size	Artikelnummer Item no.
1	Frontschild	Front label	1		
2	Sicherheitsschild	Safety label	1		
3	Maschinenschild	Machine label	1		
4	Hinweisschild	Instruction label	1		
5	Sicherheitsschild	Safety label	1		
6	Hinweisschild	Instruction label	1		
7	Gewindeschneidtablelle	Tapping table	1		03425001607

TU2506_TU2506V_parts.fm

M Maschinenschilder - Machine labels TU 2506 V

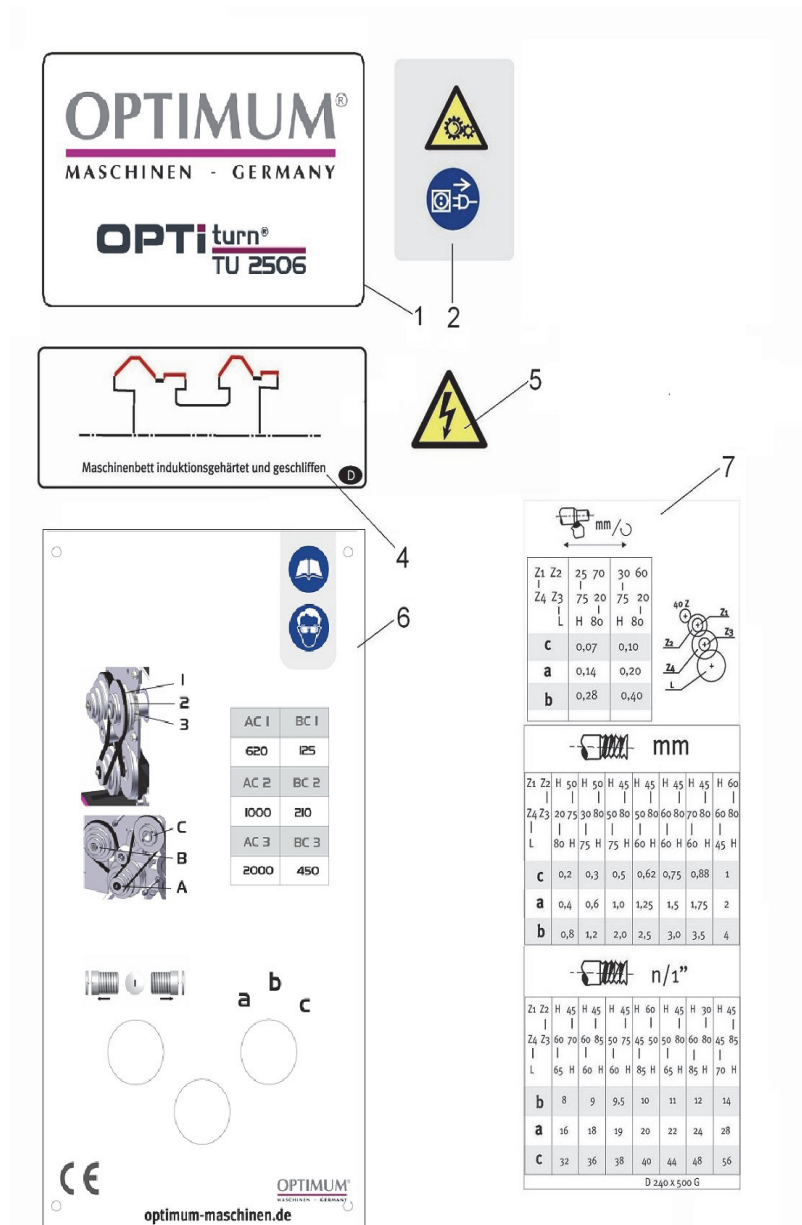

Abb. 1-13: Maschinenschilder - Machine labels

Maschinenschilder - Machine labels TU2506 V					
Pos.	Bezeichnung	Description	Menge Qty.	Grösse Size	Artikelnummer Item no.
1	Frontschild	Front label	1		
2	Sicherheitsschild	Safety label	1		
3	Maschinenschild	Machine label	1		
4	Hinweisschild	Instruction label	1		
5	Sicherheitsschild	Safety label	1		
6	Hinweisschild	Instruction label	1		03425006L06
7	Gewindeschneidtable	Tapping table	1		

TU2506_TU2506V_parts.fm

Ersatzteilliste - Spare parts list - TU2506 TU2506V					
Pos.	Bezeichnung	Description	Menge Qty.	Grösse Size	Artikelnummer Item no.
1	Griff Klemmhebel	Handle locking lever	1		0342500101
3	Klemmmutter Werkzeughalter	Clamping nut tool holder	1		0342500103
4	Beilagscheibe Klemmmutter	Washer clamping nut	1		0342500104
5	Klemmschraube	Clamping screw	8		03420321748
6	Vierfachstahhalter	Quadruple tool holder	1		03420550747
7	Andruckleiste Oberschlitten	Pressure border top slide	1		0342500107
8	Oberschlitten	Top slide	1		0342500108
8	Oberschlitten komplett	Top slide complete	1		0342500108CPL
9	Gewindebolzen Vierfachstahhalter	Threaded rod quadruple tool holder	1		0342500109
10	Rastbolzen	Fixing pin	1		03420321762
11	Feder	Spring	1		
12	Spannstift	Spring pin	1	ISO 8752 - 4x10 - A	
13	Mutter	Nut	5	ISO 4032 - M4	
14	Innensechskantschraube	Socket head screw	5	GB 70-85 - M4 x 30	
16	Schwalbenschwanzführung Oberschlitten	Dove tail guidance top slide	1		0342500120
17	Klemmring Oberschlitten	Clamping ring top slide	1		0342500117
18	Skalenring Winkelskala Oberschlitten	Angle scales ring top slide	1		0342500118
19	Innensechskantschraube	Socket head screw	1	GB 70-85 - M6 x 16	
20	Spindel Oberschlitten	Spindle top slide	1	M8x1,25 L	0342500120
22	Lagerbock Spindel Oberschlitten	Saddle spindle top slide	1		0342500122
23	Skalenring Handrad Oberschlitten	Scales ring handwheel top slide	1		0342500123
24	Führungsscheibe Skalenring	Guide disk scales ring	1		0342500124
25	Hebel Handrad Oberschlitten	Lever handle	1		0342500125
26	Handgriff Handrad	Handle handwheel	3		0342500126
27	Befestigungsschraube Griff Handrad	Fixing bolt for handle handwheel	1		0342500127
32	Bügel	Holder	1		
33-1	Innensechskantschraube	Socket head screw	2	GB 70-85 - M4 x 10	
33-2	Scheibe	Washer	2	DIN 125-1 4 mm	
34	Senkschraube mit Kreuzschlitz	Countersunk screw	2	DIN EN ISO 7046/ M5 x 8	
35	Welle	Shaft	1		
36	Späneschutzschild	Splinter shield	1		0340401
37	Sechskanthülse	Hexagonal case	1		
38-1	Innensechskantschraube	Socket head screw	2	GB 70-85 - M3 x 8	
38-2	Mutter	Nut	1	ISO 4035 M3	
39-1	Innensechskantschraube	Socket head screw	2	GB 70-85 - M3 x 8	
39-2	Scheibe	Washer	2	DIN 125-1 3 mm	
40	Oler	Oiler	11	6 mm	0340105
42	Innensechskantschraube	Socket head screw	2	GB 70-85 - M5 x 10	
43	Planschlitten	Cross slide	1		0342500143
44	Spannstift		2	ISO 8752 - 5 x 26	
45	Stellschraube	Set screw	5	M5x40	03420321519
46	Sechskantmutter	Hexagon nut	4	ISO 4035 - M5	
48	Andruckleiste Planschlitten	Pressure border cross slide	1		0342500148
49	Spindel inkl. Mutter	Spindle with nut	1		0342500149
52	Schwalbenschwanzführung Planschlitten	Dove tail guidance cross slide	1		0342500152
54	Abstreifer	Cleaner	1		0342500154
55	Halter Abstreifer	Holder for cleaner	1		0342500155
56	Scheibe	Washer	1		
57	Andruckleiste Bettschlitten	Pressure border bed slide	1		0342500157
58	Kreuzschlitz-Flachkopf-Gewindeschneidschrauben	Cross slot flat head thread cut screw	4	GB 6560-86 - M3x8	
59	Passfeder	Key	1		
61	Innensechskantschraube	Socket head screw	1	GB 70-85 - M5 x 10	
62	Lagerbock Spindel Planschlitten	Saddle spindle cross slide	1		0342500162
64	Innensechskantschraube	Socket head screw	3	GB 70-85 - M8 x 20	
65	Skalenring Planschlitten	Scales ring cross slide	1		0342500165
66	Handrad Planschlitten	Handwheel cross slide	1		0342500166
67	Oler	Oiler	1	10 mm	
68	Buchse	Socket	1		
69	Axial Rillenkugellager	Axially grooved ball bearing	2	51101	04051101
70	Hülse	Case	1		
71	Schlosskasten	Apron	1		0342500171
72	Handrad Bettschlitten	Handwheel bed slide	1		0342500172

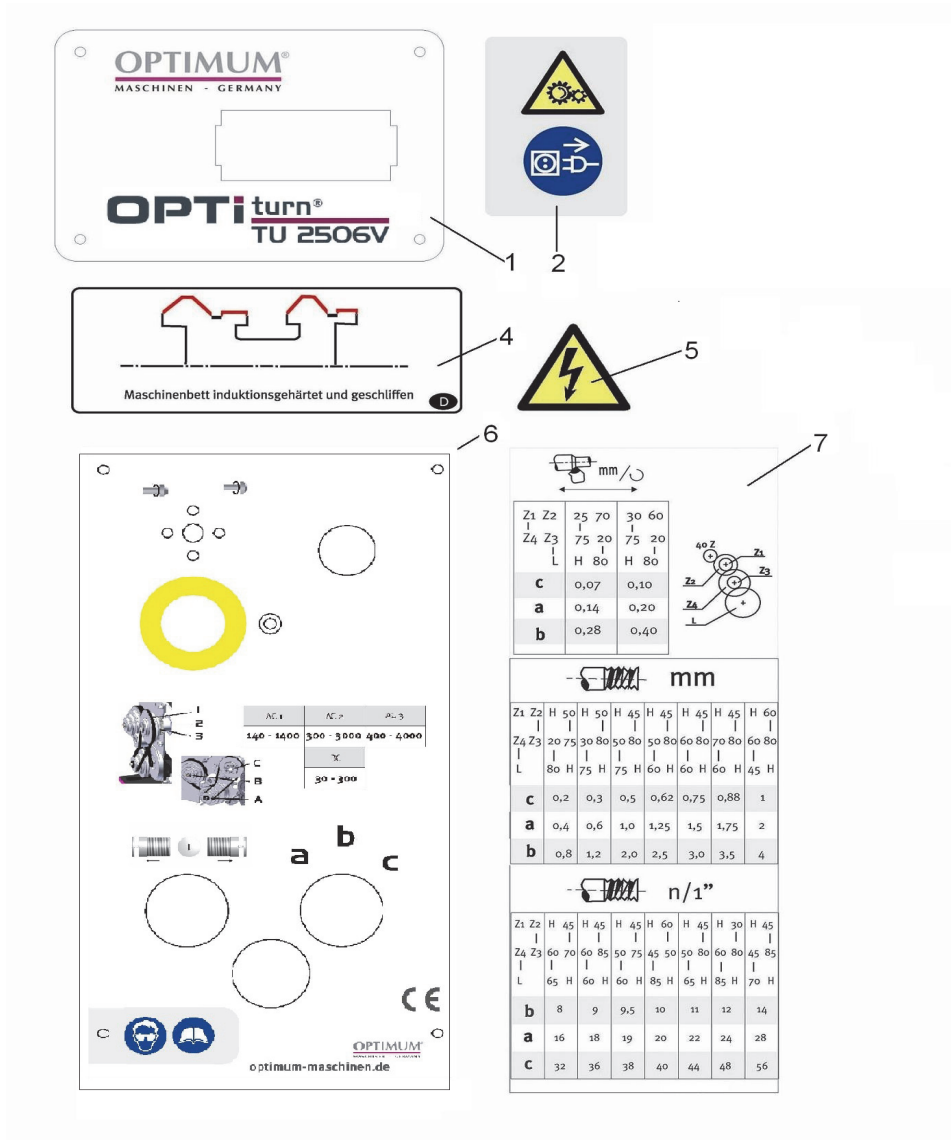
TU2506_TU2506V_parts.fm

Ersatzteilliste - Spare parts list - TU2506 TU2506V					
Pos.	Bezeichnung	Description	Menge Qty.	Grösse Size	Artikelnummer Item no.
73	Griff Handrad Bettschlitten	Handle handwheel bed slide	1		0342500126
74	Befestigungsschraube Griff Handrad	Fixing bolt handle handwheel	1		0342500127
75-1	Zahnrad	Toothed wheel	1		03425001751
75-2	Verzahnte Welle	Toothed shaft	1		0342500175-2
79	Gewindestift mit Schlitz und langen Zapfen	Threaded pin with tap	2	ISO 7435 - M4 x 12	
80	Verzahnte Welle	Toothed shaft	1		0342500180
81	Passfeder	Key	1	DIN 6885 - A 4 x 4 x 12	042P4412
82	Innensechskantschraube	Socket head screw	6	GB 70-85 - M4 x 8	
83	Scheibe	Washer	1	ISO 7090 - 8 - 140 HV	
84	Sechskantmutter	Hexagon nut	1	DIN 6924 - M8	
85	Innensechskantschraube	Socket head screw	4	GB 70-85 - M8 x 35	
86	Skalenring Handrad Bettschlitten	Scales ring handwheel bed slide	1		0342500186
87	Flansch	Flange	1		0342500187
89	Scheibe Einrückhebel Vorschub	Disc for lever longitudinal feed	1		0342500189
90	Bewegungsscheibe Schlossmutter	Movement disk	1		0342500190
91	Zylinderstift	Cylindrical pin	2	ISO 2338 - 5 h8 x 12	
92	Schlossmutter	Lock nut	1		0342500192
93	Andruckleiste Schlossmutter	Pressure border lock nut	1		
95	Gewindestift mit Schlitz und langen Zapfen	Threaded pin with tap	1	ISO 7435 - M4 x 20	
96	Sechskantmutter	Hexagon nut	4	ISO 4032 - M5	
97	Welle Bewegungsscheibe	Shaft movement disk	1		
98	Zylinderstift	Cylindrical pin	1	ISO 2338 - 3 h8 x 18	
99	Gewindestift mit Schlitz und langen Zapfen	Threaded pin with tap	1	ISO 7435 - M4 x 12	
99	Buchse	Socket	1		
100	Stellschraube	Set screw	3	M5 x 40	
101	Gewindestift	Threaded pin	1	ISO 4027 - M4 x 8	
102	Flansch	Flange	1		03420321403
104	Federstück	Spring piece	1		
105	Spannstift	Spring pin	2	ISO 8752 - 4 x 16 - A	
106	Paßfeder	Key	2	DIN 6885 - A 3 x 3 x 10	042P3310
107	Scheibe	Washer	1		
108	Sechskantmutter	Hexagon nut	1	DIN 6924 - M8	
109	Nutenschraube	Slot screw	2		03425001109
110	Sechskantmutter	Hexagon nut	2	ISO 4035 - M8	
111	Scheibe	Washer	2	DIN 125-1 - B 8.4	
115	Stellschraube	Set screw	5	M5x15	
116	Sechskantmutter	Hexagon nut	5	ISO 4032 - M5	
117	Innensechskantschraube	Socket head screw	7	GB 70-85 - M5 x 16	
118	Führungsleiste Bettschlitten	Guide rail bed slide	1		03425001118
119	Innensechskantschraube	Socket head screw	4	GB 70-85 - M5 x 25	
121	Klemmteil	Clamping part	1		03425001121
122	Bettschlittenführung	Bed slide guidance	1		03425001122
124	Lagerbuchse	Bushing	1		
125	Innensechskantschraube	Socket head screw	2	GB 70-85 - M8 x 30	
126	Halter Abstreifer	Holder for cleaner	1		03425001126
127	Abstreifer	Wiper	1		03425001127
128	Innensechskantschraube	Socket head screw	2	GB 70-85 - M3 x 6	
129	Rastblech Einrückhebel Vorschub	Rest sheet metal engaging lever feed motion	1		03425001129
130	Gewindestift	Threaded pin	2	ISO 4028 - M6 x 16	
131	Gewindestift	Threaded pin	1	ISO 4026 - M6 x 6	
132	Feder Wahlschalter	Spring rotary switch	1		
133	Stahlkugel	Steel ball	1	5 mm	042KU05
134	Griff Einrückhebel	Handle engaging lever	1		03425001134
135	Sprengring	Circlip	1	DIN 7993 - A 7	
136	Welle Einrückhebel	Shaft engaging lever	1		03425001136
137	Feder	Spring	1		03425001137
138	Zylinderschraube mit Schlitz	Cheese head screw with slot	1	ISO 1207 - M5 x 8	
139	Federblech	Spring plate	1		
140	Passfeder	Key	1	DIN 6885 - A 5 x 5 x 10	042P5510
141	Buchse	Socket	1		
207	Paßfeder	Key	1	DIN 6885 - A 5 x 5 x 50	042P5550
208	Innensechskantschraube	Socket head screw	1	GB 70-85 - M6 x 25	
209	Sicherungsscheibe	Fixing disc	1		
228	Sechskantmutter	Hexagon nut	4	ISO 4035 - M8	

Ersatzteilliste - Spare parts list - TU2506 | TU2506V

Pos.	Bezeichnung	Description	Menge Qty.	Grösse Size	Artikelnummer Item no.
229	Gewindestift	Threaded pin	4	DIN 835 - M8 x 35	
230	Scheibe	Washer	4	DIN 125-2 - B 8.4	
231-1	Motor 230V	Motor 230V	1		03420321101S
231-2	Motor 400V	Motor 400V	1		0342401
235	Maschinenbett	Machine bed	1		03425001235
236	Zahnstange	Rack	2		03425001236
237	Senkschraube	Countersunk screw	6	ISO 7046-1 - M5 x 12 - 4.8	
238	Leitspindel	Lead screw	1	TR 20 x 3	03425001238
239	Verbindungsstueck	Connecting piece	1		03425001239
240	Innensechskantschraube	Socket head screw	2	GB 70-85 - M6 x 14	
242	Lagerbock	Saddle	1		03425001242
243	Zylinderstift	Cylindrical pin	6	GB 120-86 - 6 x 16	
244	Scheibe	Washer	2	DIN 125 - A 10.5	
245	Nutmutter	Groove nut	2	DIN 1804 - M12	
250	Scheibe	Washer	4	DIN 125 - A 8.4	
251	Innensechskantschraube	Socket head screw	4	GB 70-85 - M8 x 35	
256	Sechskantmutter	Hexagon nut	3	GB 6170-86 - M10	
257	Bolzen Futterflansch	Pin jaw chuck flange	3		
258	Scheibe	Washer	3	GB 95-85 - 10	
259	Innensechskantschraube	Socket head screw	4	GB 70-85 - M8 x 20	
262	Drehfutterschlüssel	Key for 3 - jaw chuck	1	10 mm	0340201
263	Schalergehäuse	Switch housing	1		03425001263
264-1	Schalterkombination 230V	Switch combination 230V	1		03420321111
264-2	Schalterkombination 400V	Switch combination 400V	1		03420550111
265	Flachkopfschraube mit Kreuzschlitz	Cheese head screw	2	ISO 7045 - M4 x 16	
266	Innensechskantschraube	Socket head screw	4	GB 70-85 M3 x 8	
267	Sichtfenster Drehfutterschutz	Sight jaw chuck protection	1		
268	Spannstift	Spring pin	1	GB 879-86 5 x 18	
269	Rahmen Drehfutterschutz	Frame jaw chuck protection	1		03425001269
270	Scheibe	Washer	4	DIN 125-1 A 3.2	
271	Mutter	Nut	4	DIN EN 24 032 M3	
272	Welle Drehfutterschutz	Shaft jaw chuck protection	1		
273	Halter Drehfutterschutz	Fixing part jaw chuck protection	1		
274	Positionsschalter Drehfutterschutz	Position switch jaw chuck protection	1		0460016
275	Scheibe	Washer	2	DIN 125 - A 6.4	
276	Innensechskantschraube	Socket head screw	6	GB 70-85 - M6 x 10	
277	Zugentlastung Anschlusskabel	Strain relief connection cable	1	PG 19	
278	Stiftschraube	Threaded pin	1	DIN 915 M5 x 12	
279	Deckel Schaltergehäuse	Cover switch housing	1		03425001279
295	Axial-Rillenkugellager	Deep groove ball thrust bearing	2	51102	04051102
297	Messing Abscherstift	Brass shear pin	1		
298	Zylinderstift	Cylindrical pin	1	ISO 2338 - 5 m6 x 22	
301	Sicherungsring	Circlip	2	DIN 471 - 18 x 1.2	042SR18W
302	Zahnrad	Gear wheel	1	24 Z m1.25 15 mm	03425001302
304	Welle	Shaft	1		
305	Sicherungsring	Circlip	1	DIN 471 - 16 x 1	042SR16W
306	Zahnrad	Gear wheel	1	24 Z m1.25 6 mm	03425001306
307	Paßfeder	Key	1	DIN 6885 - A 4 x 4 x 20	042P4420
308	Paßfeder	Key	1	DIN 6885 - A 4 x 4 x 45	
309	Welle	Shaft	1		03425001309
310	Zahnradkombination	Gear wheel combination	1		03425001310
311	Gehäuse Vorschubgetriebe	Housing feed gear	1		03425001311
312	Ölverschlußschraube	Oil plug	2		03425001312
314	Buchse	Socket	1		
315	Innensechskant-Gewindestift mit Spitze	Allan screw with point	2	GB 78-85 - M6 x 10	
316	Flansch	Flange	1		03425001316
319	Eingangswelle	Entrance shaft	1		03425001319
320	Gleitlager	Sliding bearing	1		
321	Zahnrad	Gear wheel	1	32 Z m1.25 6 mm	03425001321
324	verzahnte Welle	toothed shaft	1	16Z m1.25	03425001324
325	Paßfeder	Key	2	DIN 6885 - A 4 x 4 x 8	
326	Sicherungsring	Circlip	2	DIN 471 - 15 x 1	042SR15W
327	Zahnrad	Gear wheel	1	24 Z m1.25 6 mm	03425001327
328	Rillenkugellager	Grooved ball bearing	2	6202	0406202R
329	Flansch	Flange	1		03425001329
330	Innensechskantschraube	Socket head screw	6	GB 70-85 - M5 x 14	

TU2506_TU2506V_parts.fm

Ersatzteilliste - Spare parts list - TU2506 TU2506V					
Pos.	Bezeichnung	Description	Menge Qty.	Grösse Size	Artikelnummer Item no.
331	Deckel Vorschubgetriebe	Cover feed gear	1		
332	Innensechskantschraube	Socket head screw	5	GB 70-85 - M6 x 12	
334	Stahlkugel	Steel ball	2	5 mm	042KU05
335	Wahlschalter	Rotary switch	2		03425001335
336	Druckfeder	Spring	2		
337	Spannstift	Spring pin	2	ISO 8752 - 5 x 16	
338	O-Ring	O-ring	2	DIN 3771 - 7.1 x 1.8	
339	Welle Wahlschalter	Shaft rotary switch	2		03425001339
340	Verstellhebel	Adjusting lever	2		03425001340
341	Getriebegabel	Transmission fork	1		03425001353
342	Markierung Wahlschalter	Marking rotary switch	2		03425001342
343	Zylinderstift	Cylindrical pin	1	ISO 2338 - 3 h8 x 14	
344	Mitnehmerhuelse	Case	1		03427001344
345	Scheibe	Washer	1		
346	Rueckwanddeckel	Backwall cover	1		
347	Senkschraube mit Kreuzschlitz H	Countersunk screw	10	GB 819-85 - M5x8	
348	O-Ring	O-ring	2	DIN 3771 - 15 x 1.8	
349	Buchse rechts	Socket right	1		03425001349
350	Gleitlager Zwischenwelle	Sliding bearing intermediate shaft	1		
351	Gewindestift	Threaded pin	2	DIN 915 - M5 x 8	
353	Getriebegabel	Transmission fork	1		03425001353
354	Innensechskantschraube	Socket head screw	4	GB 70-85 - M6 x 50	
360	Oelschauglas	Oil sight glass	1	25 mm	
361	O-Ring	O-ring	1	DIN 3771 - 20 x 2.65	
403	Stiftschraube	Threaded pin	2	GB 897-88 - A M10x120	
404	Sechskantmutter	Hexagon nut	7	ISO 4032 - M10	
405	Mutter Schutzabdeckung	Nut protection cover	1		03420321120
406	Spindel	Spindle	1		03425001406
407	Paßfeder	Key	1	DIN 6885 - A 8 x 7 x 40	042P8740
408	Lagerabdeckung vorne	Bearing cover in front	1		03425001408
414	Kegelrollenlager	Taper roller bearing	2	32009	04032009
415	Lagerabdeckung hinten	Bearing cover in in the back	1		03425001415
416	Distanzhülse	Spacer	1		03425001416
417	Zahnrad	Toothed wheel	1	40 Z, m1,5	03425001417
419	Keilriemen	V - belt	1	10 x 750 Li	0391290
420	Spindelkeilriemenscheibe	Spindle V-belt pulley	1	~50Hz	03425001420
	Spindelkeilriemenscheibe	Spindle V-belt pulley	1	~60Hz	0342500142060Hz
421	Innensechskantschraube	Socket head screw	4	GB 70-85 - M5 x 10	
423	Wellenmutter	Shaft nut	1		03425001423
424-1	Welle	Shaft	1		034250014241
424-2	Hülse	Case	1		034250014242
425	Zahnriemen	Toothed belt	1	230XL 070	0395350
427	Zahnriemenscheibe	Toothed belt disk	1	~50Hz	03420321133
	Zahnriemenscheibe	Toothed belt disk	1	~60Hz	0342032113360Hz
428	Sicherungsring	Circlip	1	DIN 471 - 12 x 1	042SR121
430	Zahnriemenscheibe	Toothed belt disk	1		03420321123
430-2	Bundscheibe vorne	Flanged washer in front	1		
430-1	Bundscheibe hinten	Flanged washer in the back	1		
431	Motorkeilriemenscheibe	Motor V-belt pulley	1	~50Hz	03420321125
	Motorkeilriemenscheibe	Motor V-belt pulley	1	~60Hz	0342032112560Hz
433	Scheibe	Washer	1	DIN 125 - A 8.4	
434	Sechskantmutter	Hexagon nut	1	ISO 4032 - M8	
435	Klemmstück	Clamping piece	1		03425001435
436	Exzentrumscheibe Spannrolle	Eccentric disk idler	1		03420321218
437	Welle Spannrolle	Shaft for idler	1		03425001437
438	Rillenkugellager	Grooved ball bearing	1	6001	0406001R
439	Spannrolle	Idler	1		03425001439
440	Sicherungsring	Circlip	1	DIN 472 - 28 x 1.2	042SR281
441	Schutzabdeckung Spindelstock	Protection cover headstock	1		03425001441
441-1	Scheibe	Washer	1	DIN 125 - A 5.3	
441-2	Zylinderschraube mit Schlitz	Cheese head screw with slot	1	ISO 1207 M 5 x 8	
441-3	Faldeckel	Drop cover	1		
442	Sicherungsring	Circlip	2	DIN 471 - 12 x 1	
451	Hülse	Case	1		
452	Sechskantmutter	Hexagon nut	1	ISO 4032 - M10	
453	Sechskantmutter	Hexagon nut	1	ISO 4032 - M12	
454	Sechskantmutter	Hexagon nut	1	ISO 4035 - M12	
455	Scheibe	Washer	1	DIN 125 - A 13	
470	Grundplatte	Baseplate	1		
472	Scheibe	Washer	3	DIN 125 - A 10.5	

Ersatzteilliste - Spare parts list - TU2506 | TU2506V

Pos.	Bezeichnung	Description	Menge Qty.	Grösse Size	Artikelnummer Item no.
473	Innensechskantschraube	Socket head screw	2	GB 70-85 - M10 x 20	
475	Bolzen	Bolt	1		
476	Scheibe fuer Zahnriemenscheibe	Disk for toothed belt disk	1		03425001476
502	Innensechskantschraube	Socket head screw	1	DIN 912 M8 x 35	
503	Wechselradschiene	Change gear train	1		03427001503
504	Lagerbock Wechselradschiene	Saddle change gear train	1		
505	Innensechskantschraube	Socket head screw	3	DIN 912 M5 x 10	
506	Wechselrad, t=9 mm, Di=14 mm	Change gear	1	85 Zähne, Modul 1,5	0342500150585
507	Wechselrad, t=9 mm, Di=14 mm	Change gear	1	80 Zähne, Modul 1,5	0342500150580
508	Wechselrad, t=9 mm, Di=14 mm	Change gear	1	75 Zähne, Modul 1,5	0342500150575
509	Wechselrad, t=9 mm, Di=14 mm	Change gear	1	65 Zähne, Modul 1,5	0342500150565
510	Wechselrad, t=9 mm, Di=14 mm	Change gear	2	60 Zähne, Modul 1,5	0342500150560
512	Wechselrad, t=9 mm, Di=14 mm	Change gear	1	70 Zähne, Modul 1,5	0342500150570
511	Wechselrad, t=9 mm, Di=14 mm	Change gear	1	50 Zähne, Modul 1,5	0342500150550
514	Wechselrad, t=9 mm, Di=14 mm	Change gear	1	45 Zähne, Modul 1,5	0342500150545
515	Wechselrad, t=9 mm, Di=14 mm	Change gear	1	30 Zähne, Modul 1,5	0342500150530
516	Wechselrad, t=9 mm, Di=14 mm	Change gear	1	20 Zähne, Modul 1,5	0342500150520
517	Nutenstein Wechselradschiene	Groove stone change gear	2	M5	03425001517
518	Distanzscheibe	Shim	1	1,5 mm	03425001518
519	Distanzscheibe	Shim	1	3 mm	03425001519
520	Verbindungshülse Wechselräder	Connecting case of change gears	2		03427001344
521	Klemschraube Wechselrad	Clamping screw change gear	2	ab Bj. 2008	03425001521
521A	Klemmschraube Wechselrad	Clamping screw change gear	2	bis Bj. 2008	03425001521A
522	Befestigungsring	Attachment ring	1		03425001522
523	Hülse Wechselrad	Case change gear	1		03425001523
524	Scheibe	Washer	1		03425001524
525	Innensechskantschraube	Socket head screw	1	DIN 912 M6 x 10	
600	Motorabdeckung	Motor cover	1		03420321802
601	Spritzwand D240x500G	Splash wall D240x500G	1		03425001601
601	Spritzwand D240x500 DC Vario	Splash wall D240x500 DC Vario	1		03425006601
602	Kreuzschlitzschraube	Cross slot flat head screw	6	GB 6560-86 - M5x10	
603	Abdeckblech	Cover plate	1		
605	Innensechskantschraube	Socket head screw	10	GB 70-85 - M3 x 5	
607	Gewindeschneidtafel D240x500DC Vario	Thread cutting table D240x500DC Vario	1		03425001607
611	Spänwanne D240x500G	Chip pan D240x500G	1		03425001611
611	Spänwanne D240x500DC Vario	Chip pan D240x500DC Vario	1		
612	Gummiablage	Rubber shelf	1		03425001612
615	Schaltkasten für Vario	Switch box for Vario type	1		
901	Reitstock komplett	Tailstock complete	1		03425001901CPL
902	Klemmteil Pinole unten	Clamping piece spindle sleeve down	1		
903	Klemmteil Pinole oben	Clamping piece spindle sleeve top	1		
904	Zentrierstück Pinole	Piece of centering of spindle sleeve	1		03425001904
905	Pinole komplett	Sleeve complete	1		03425001905CPL
906	Spindel	Spindle	1		03425001905CPL
907	Axial Rillenkugellager	Axially grooved ball bearing	1	51101	04051101
908	Lagerbock	Saddle	1		
909	Innensechskantschraube	Socket head screw	1		
910	Paßfeder	Key	1	DIN 6885 - A 4 x 4 x 14	042P4414
911	Skalenring	Scales ring	1		03425001911
912	Handrad	Hand wheel	1		0342500172
913	Federblech	Spring plate	1		
914	Scheibe	Washer	1	ISO 7090 - 8 - 140 HV	
915	Sechskantmutter	Hexagon nut	1	DIN 6924 - M8	
916	Hülse Griff	Case for handle	1		
917	Schraube Griff	Fixing bolt for case	1		
918	Kopf Spannhebel	Head clamping lever	1		
919	Klemmhebel	Clamping lever	1		
920	Grundplatte	Base plate	1		
921	Innensechskantschraube	Socket head screw	2	GB 70-85 - M8 x 30	
922	Zentrierstück Pinole	Piece of centering of spindle sleeve	1		03425001922
923	Klemmschraube	Clamping screw	1	M6x15	03425001923
924	Mutter	Nut	1	M6	
925	Unterlegscheibe	Washer	1	D = 6	
926	Innensechskantschraube	Socket head screw	1	GB 70-85 - M6 x 40	

TU2506_TU2506V_parts.fm

Ersatzteilliste - Spare parts list - TU2506 | TU2506V

Pos.	Bezeichnung	Description	Menge Qty.	Grösse Size	Artikelnummer Item no.
930	Gewindestift	Threaded pin	1	ISO 4028 - M4 x 5	
931	Führungsbuchse	Guide bush	1		
932	Deckel	Cover	1		
933	Senkschraube	Countersunk screw	4	ISO 2009 - M5 x 10	
934	Spannschraube	Tightening screw	1		03425001934
935	Feder	Spring	1		
936	Klemmplatte	Clamping plate	1		03425001936
937	Sechskantmutter	Hexagon nut	1	ISO 4035 - M12	
938	Scheibe	Washer	1		
939	Niet	Rivet	4		
940	Skala	Scale	1		
941	Exzenter	Eccentric cam	1		03425001941
942	Gewindestift	Threaded pin	1	ISO 4028 - M6 x 12	
944	Scheibe	Washer	1		
945	Spannhebel	Clamping lever	1		
946	Skala	Scale	1		
947	Lagerbock	Saddle	1		
948	Grundplatte Reitstock	Base plate tailstock	1		
949	Reitstock Oberteil	Tailstock upper section	1		
950	Klemmteil Pinole	Clamping part collar	1		
951	Innensechskantschraube	Socket head screw	4	GB 70-85 - M5 x 14	
952	Kopf Spannhebel	Head clamping lever	1		
953	Not-Aus-Schalter	Emergency stop button	1		0460049
954	Trafo	Transformer	1		
955	Schalter R-und L-Lauf	Change over switch	1		0460009
956	Positionsschalter Spindelstockabdeckung	Position switch headstock protection	1		0460016
957-1	Abdeckung Kondensator	Cover capacitor	1		
957-2	Abdeckung Kondensator	Cover capacitor	1		
958-1	Kondensator (230V)	Capacitor (230V)	1	25µF	
958-2	Kondensator (230V)	Capacitor (230V)	1	150µF	
C1	Frequenzumrichter	Frequency converter	1	Lenze 8200 vector	0313125
C2	Funktionsmodul	Functionmodule	1		0313105
P3	Potentiometer	Potentiometer	1	1K Ohm	0313199

1.5 Ersatzteilzeichnungen - Spare part drawings - TU2807 | TU2807V

A Oberschlitten - Top slide



Abb. 1-14: Oberschlitten - Top slide TU 2807

TU2807_TU2807V_parts.fm

B Planschlitten- Cross slide

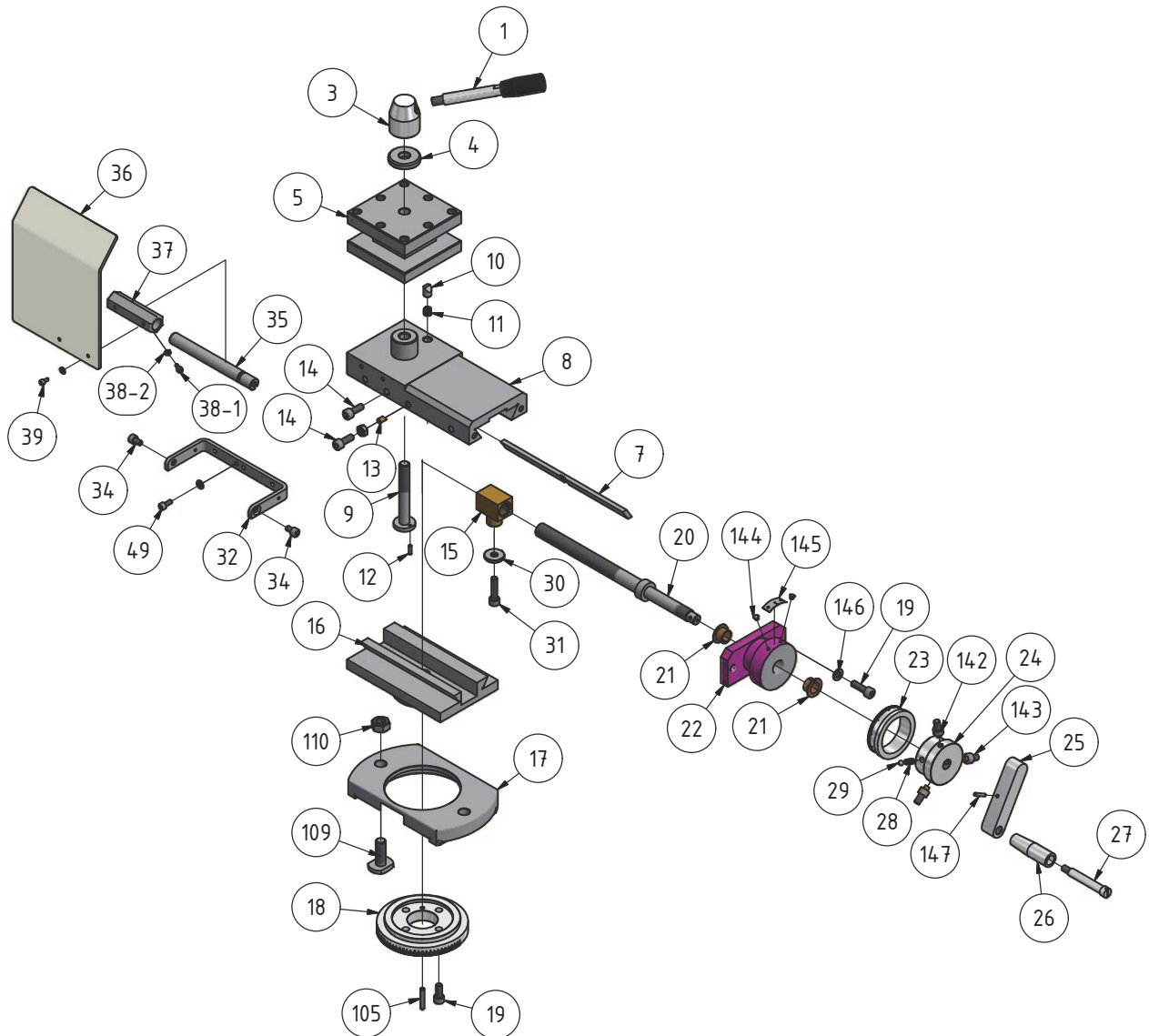

Abb. 1-15: Planschlitten - Cross slide

C Bettschlitten - Bed slide

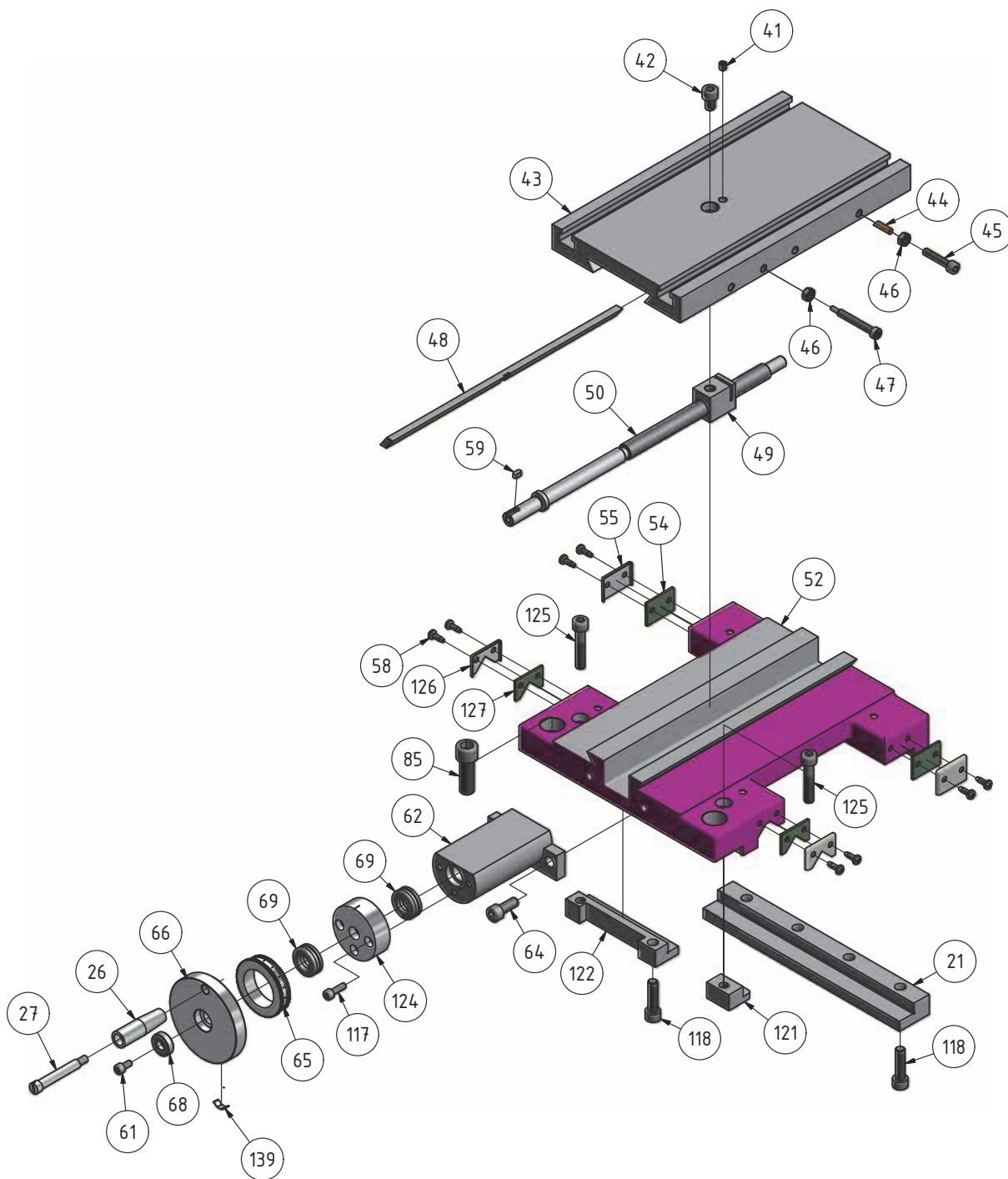

Abb. 1-16: Bettschlitten - Bed slide TU 2807

E Maschinenbett - Machine bed

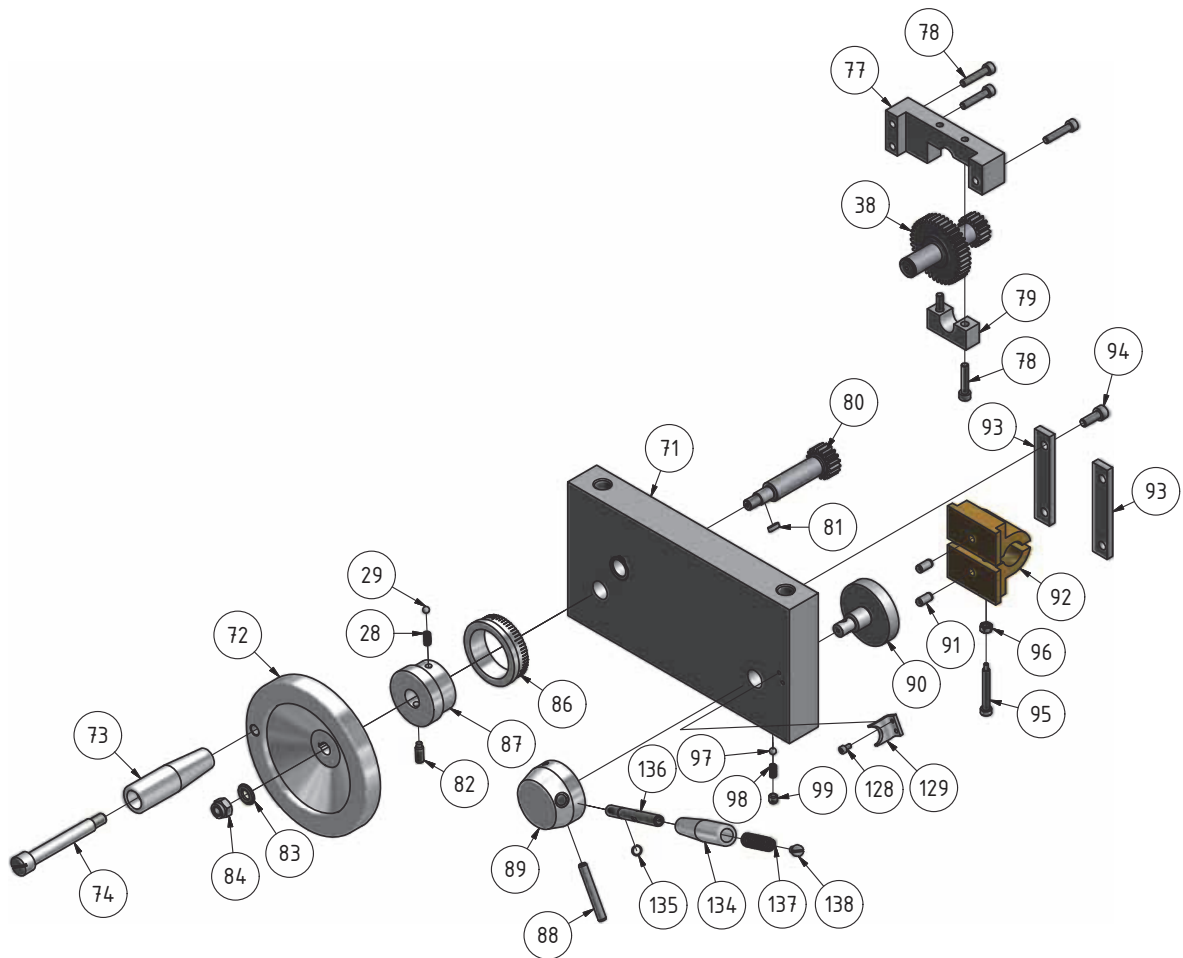

Abb. 1-18: Maschinenbett - Machine bed

F Vorschubgetriebe 1 von 2 - Feed gear 1 of 2

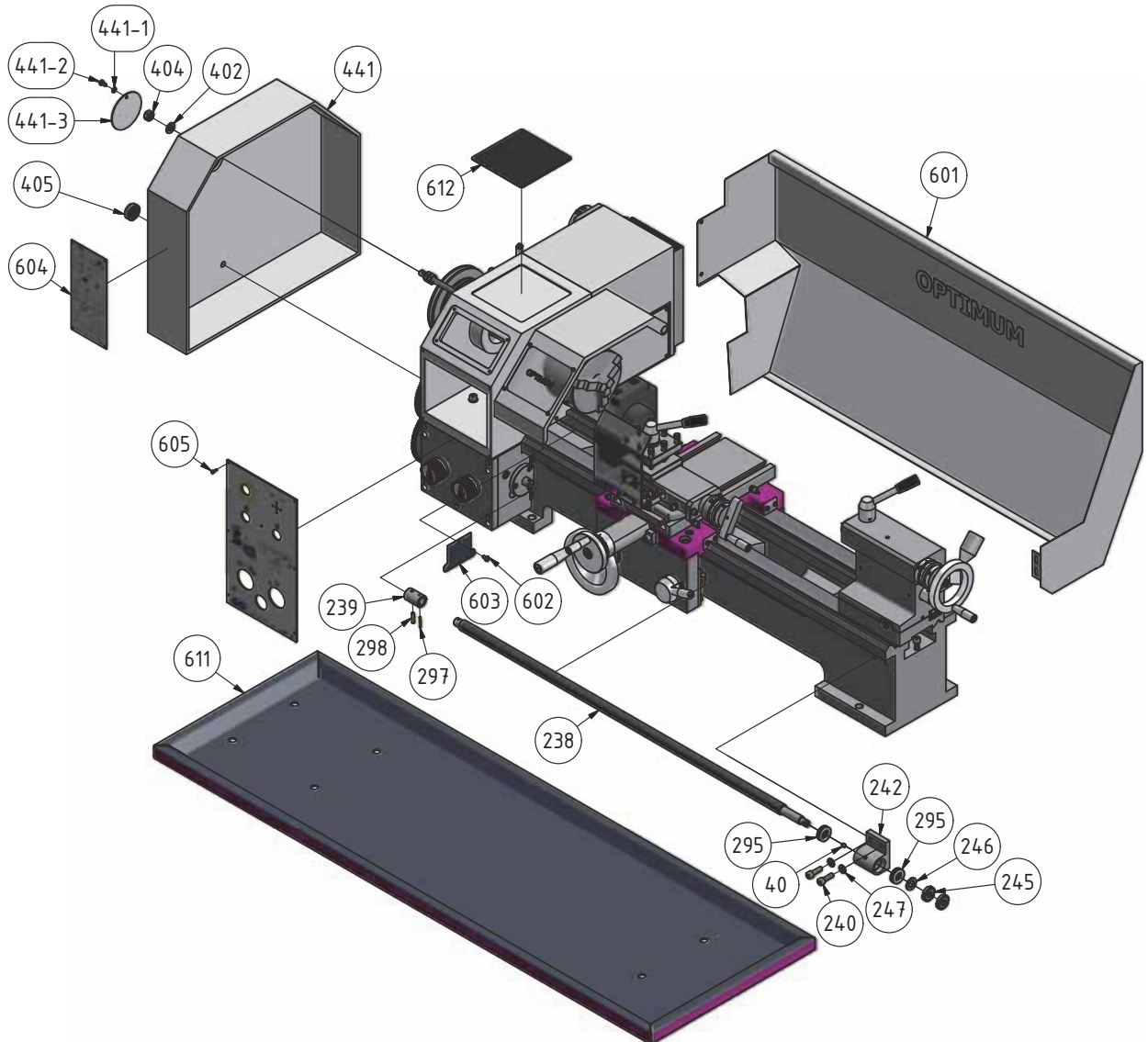

Abb. 1-19: Vorschubgetriebe 1 von 2 - Feed gear 1 of 2 - TU2807

G Vorschubgetriebe 2 von 2 - Feed gear 2 of 2

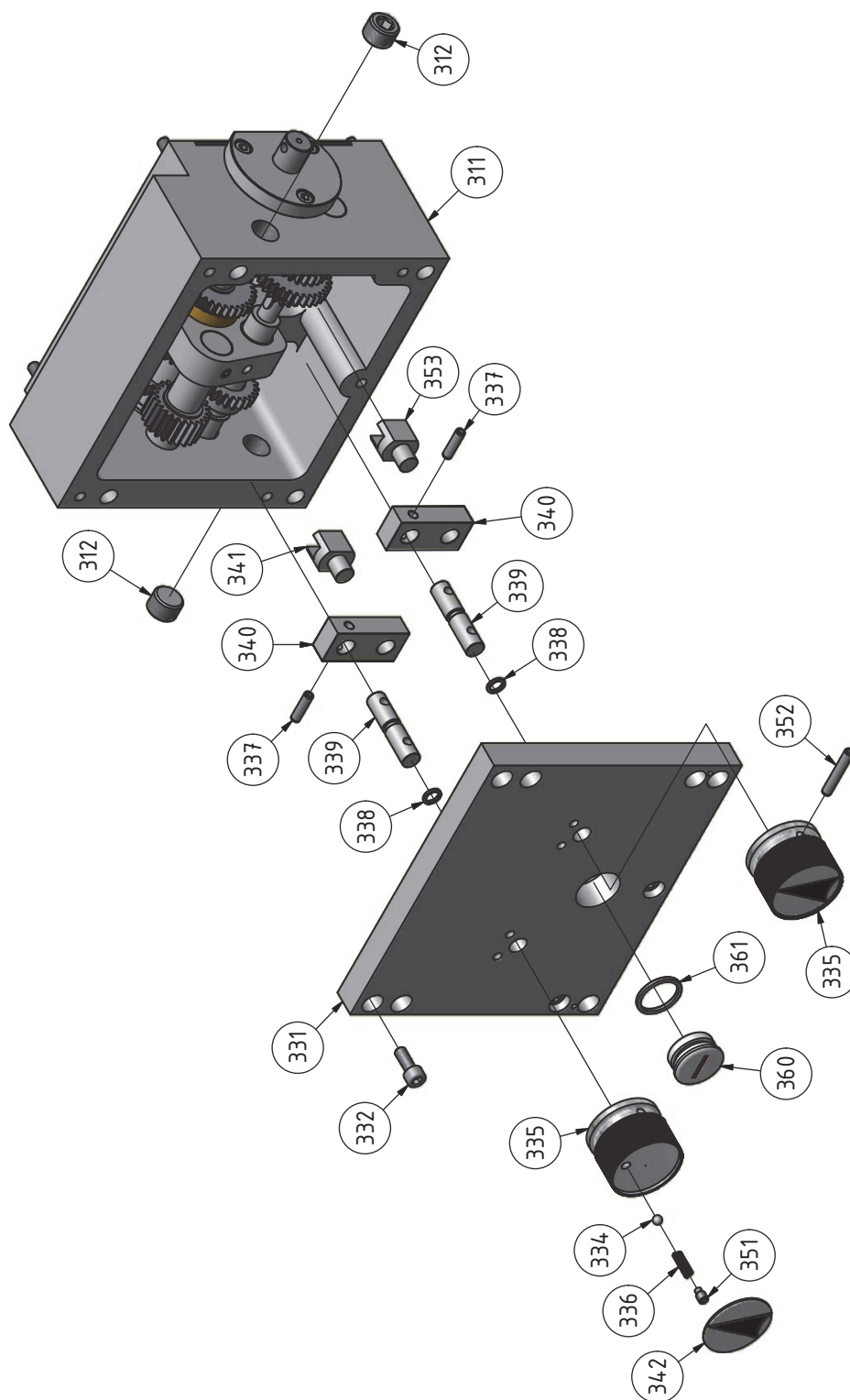

Abb. 1-20: Vorschubgetriebe 2 von 2 - Feed gear 2 of 2 - TU 2807

TU2807_TU2807V_parts.fm

J Spindelstock - Headstock TU2807V

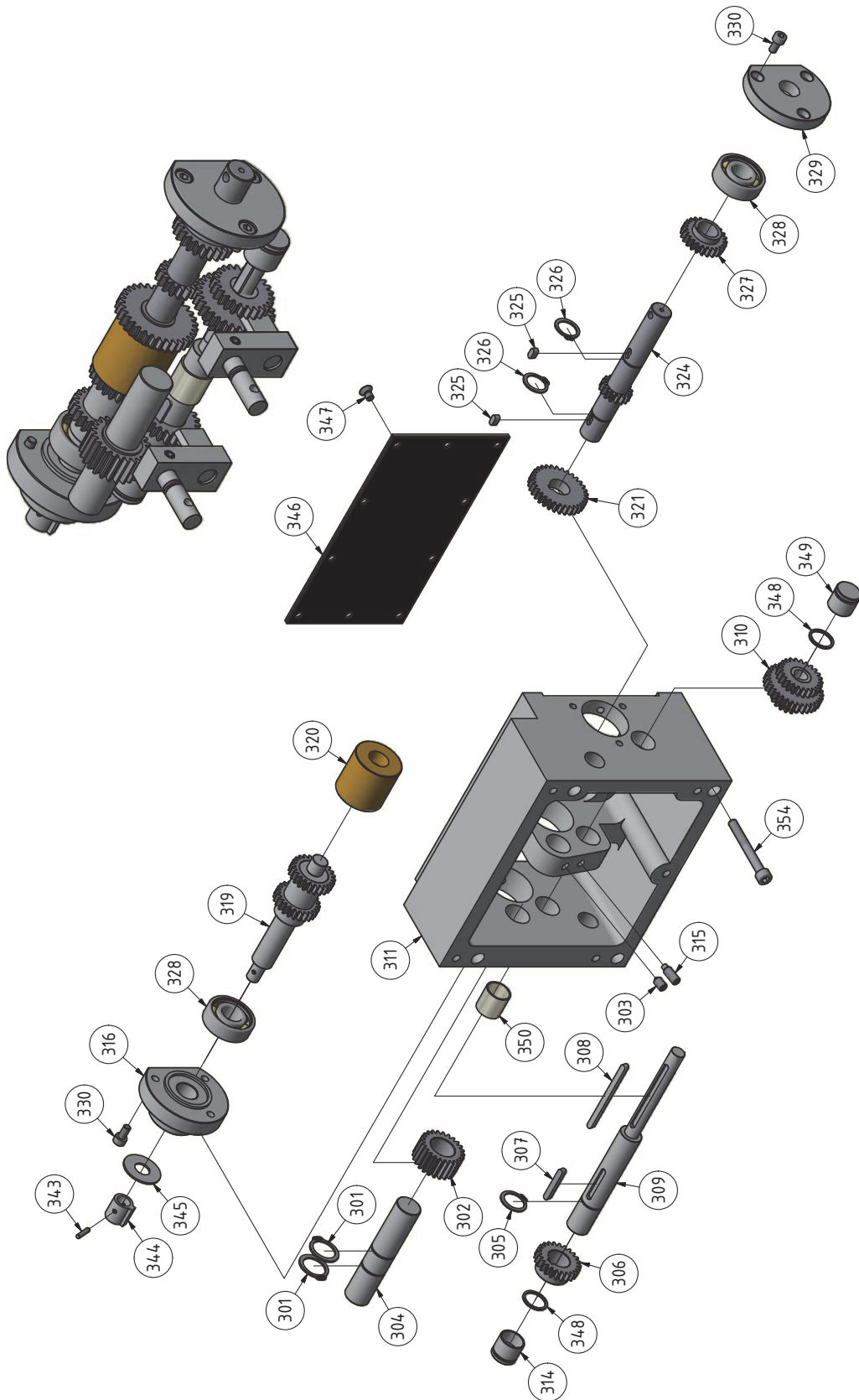

Abb. 1-23: Spindelstock - Headstock TU 2807 V

TU2807_TU2807V_parts.fm

nur TU2807V - Ersatzteilliste - Spare parts list - TU2807V only					
Pos.	Bezeichnung	Description	Menge Qty.	Grösse Size	Artikelnummer Item no.
1	Riemenscheibe	Belt pulley	1		0342700601
2	Bundscheibe	Flanged washer	1		0342700602
3	Antriebsrad	Drive gear	1		0342700603
4	Bundscheibe	Flanged washer	1		0342700604
5	Distanzscheibe	Spacer	1		0342700605
6	Motorhalterung	Motor bracket	1		0342700606
7	Passfeder	Fitting key	1	DIN 6885/A6x6x45	0342700607
8	Innensechskantschraube	Socket head screw	4	GB 70-85/M8x25	0342700608
9	Motor	Motor	1		03020245189
10	Brushlesscontroller	Brushlesscontroller	1		03021303201
11	Hauptschalter	Main switch	1		03338120S1.1
12	Sechskantmutter	Hexagon nut	4	GB 6170/M8	0342700612
13	Scheibe	Washer	4	8	0342700613
14	Bolzen	Bolt	4		0342700614
15	Endschalter Riemenabdeckung	Cover limit switch	1		0460015
16	Riemenscheibe	Belt pulley	1		0342700616
17	Riemenscheibe	Belt pulley	1		0342700617
18	Zahnriemen	Timing belt	1	240L075	0342700618
19	Keilriemen	V-belt	1	7M 875	0395250
20	Buchse	Bushing	1		0342700620
21	Innensechskanzschraube	Socket head screw	2		0342700621
22	Halterung	Bracket	1		0342700622
23	Drehzahlsensor	Rotation speed sensor	1		03338120279
24	Endschalter Drehfutterschutz	Lathe chuck cover switch	1		0460015
25	Abdeckung	Cover	1		0342700625
26	Drehfutterschutz	Lathe chuck cover	1		0342700626
27	Platte	Plate	1		0342700627
28	Potentiometer	Potentiometer	1		03338120R1.5
29	Drehzahlanzeige	Rotation speed display	1		03338120P1
30	Rechts-Links-Schalter	Change-over switch	1		0460009
31	Taste Start	Button On	1		03338453188
32	NOT-Halt Taster	Emergency stop button	1		03338120S1.2
33	Taste Aus	Button off	1		03338453187
35	Abdeckung	Cover	1		0342700635

K Wechselradgetriebe - Change gear

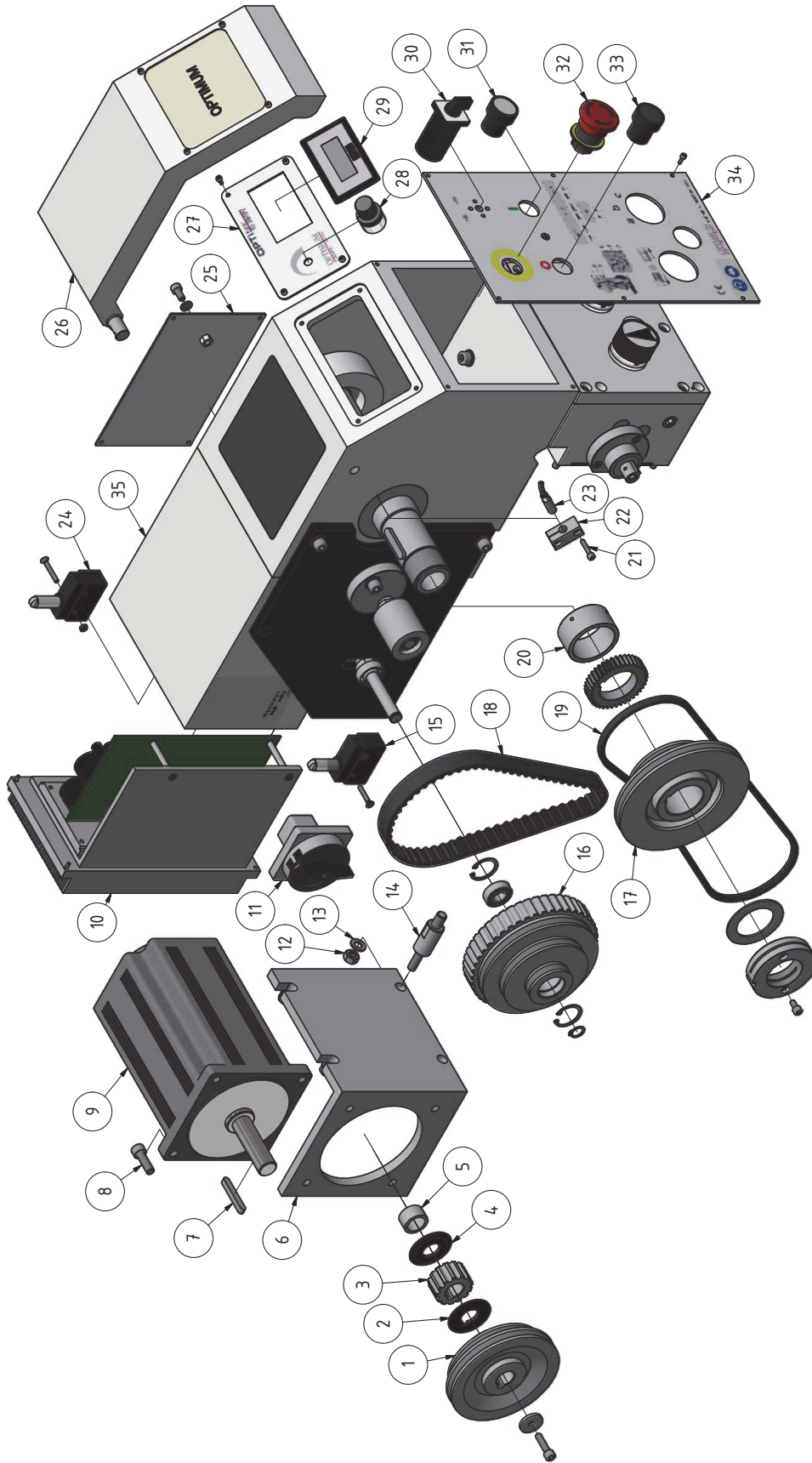

Abb. 1-24: Wechselradgetriebe - Change gear

TU2807_TU2807V_parts.fm

L Maschinenschilder - Machine labels TU 2807

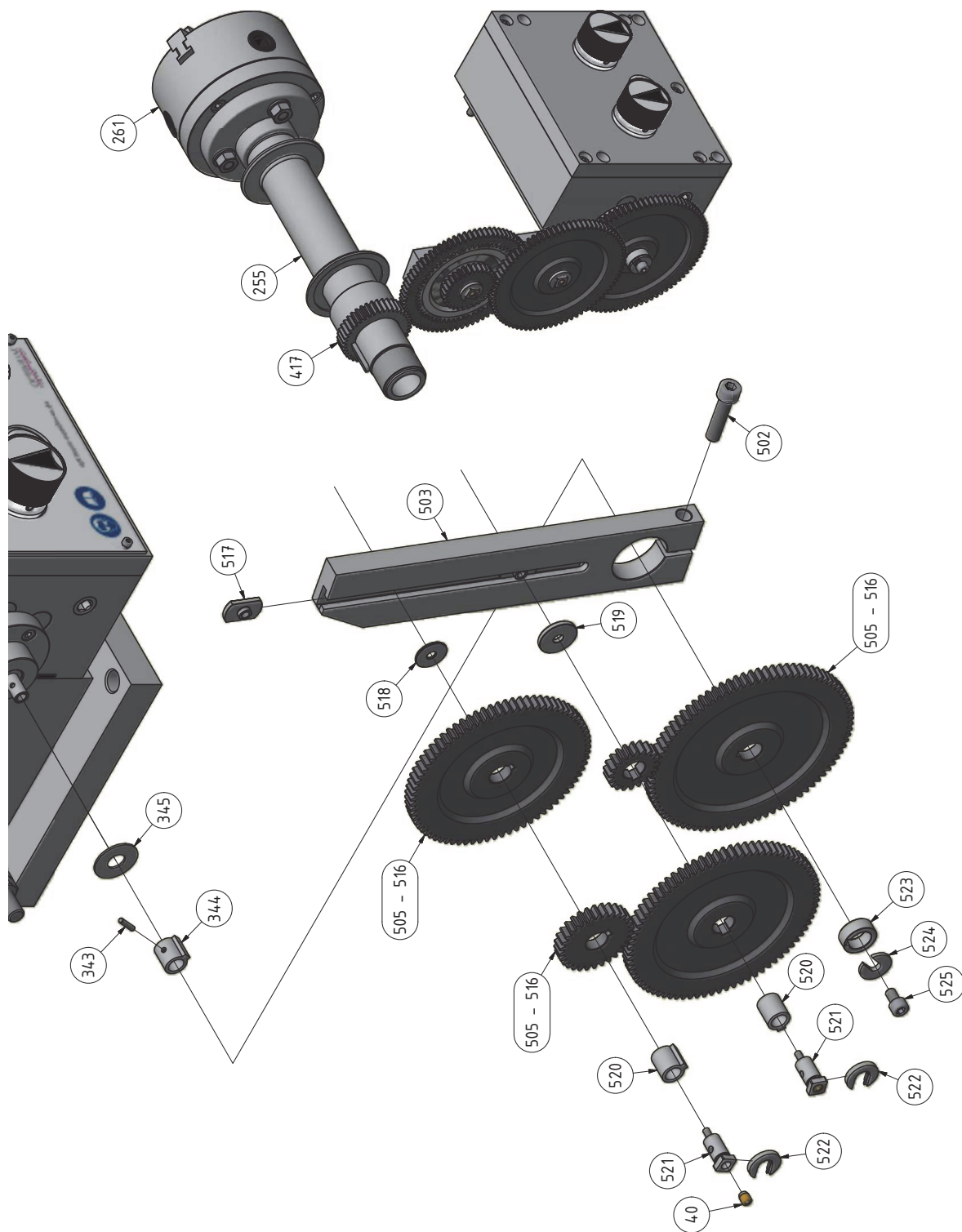

Abb. 1-25: Maschinenschilder - Machine labels

Maschinenschilder - Machine labels TU2807					
Pos.	Bezeichnung	Description	Menge Qty.	Grösse Size	Artikelnummer Item no.
1	Frontschild	Front label	1		03427001L01
2	Sicherheitsschild	Safety label	1		03425001L02
3	Sicherheitsschild	Safety label	1		03425001L05
4	Hinweisschild	Instruction label	1		03425001L04
5	Motorschild	Motor lable	1	TU2807 (230V)	03427001L05
5	Motorschild	Motor lable	1	TU2807 (400V)	03427003L05
7	Frontschild	Front label	1		03427001L07
8	Gewindeschneidtable	Tapping table	1		03427001L08

M Maschinenschilder - Machine labels TU 2807 V

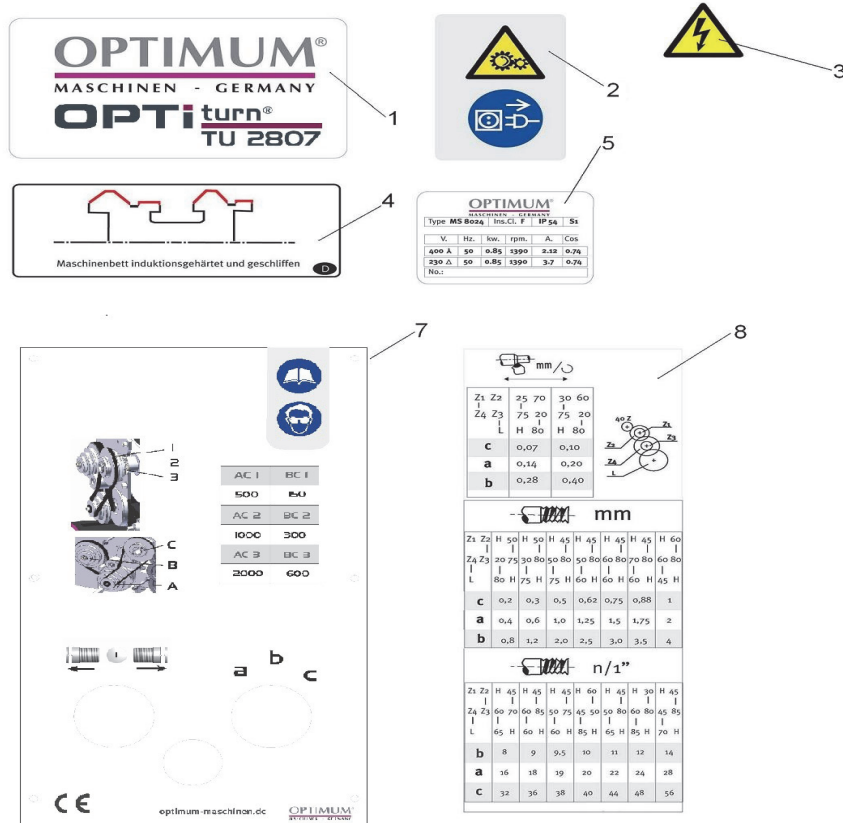

Abb. 1-26: Maschinenschilder - Machine labels

Maschinenschilder - Machine labels TU2807 V					
Pos.	Bezeichnung	Description	Menge Qty.	Grösse Size	Artikelnummer Item no.
1	Frontschild	Front label	1		03427006L01
2	Sicherheitsschild	Safety label	1		03425001L02
3	Maschinenschild	Machine label	1		03427006L03
4	Frontschild	Front label	1		03427006L03
5	Sicherheitsschild	Safety label	1		03425001L05
6	Gewindeschneidtable	Tapping table	1		03427006L06
7	Hinweisschild	Instruction label	1		03425001L04

Ersatzteilliste - Spare parts list - TU2807 TU2807V					
Pos.	Bezeichnung	Description	Menge Qty.	Grösse Size	Artikelnummer Item no.
1	Klemmhebel Wekrzeughalter	Clamping lever tool holder	1		034270011
2	Griff Klemmhebel	Handle locking lever	1		034270012
3	Klemmmutter Werkzeughalter	Clamping nut tool holder	1		034270013
4	BeilagscheibeKlemmmutter	Washer clamping nut	1		034270014
5	Vierfachstahlhalter	Quadruple tool holder	1		034270015
6	Gewindestift	Grub screw	8	GB 85-88 - M8 x 35	
7	Andruckleiste Oberschlitten	Pressure border top slide	1		034270017
8	Oberschlitten	Top slide	1		034270018
9	Gewindebolzen Vierfachstahlhalter	Threaded rod quadruple tool holder	1		034270019
10	Rastbolzen	Fixing pin	1		0342700110
11	Feder	Spring	1		0342700111
12	Spannstift	Spring pin	1	ISO 8752 - 3 x 10 A	
13	Innensechskantschraube	Socket head screw	4	GB 70-85 - M6 x 16	
14	Sechskantmutter	Hexagon nut	3	ISO 4032 - M6	
15	Spindelmutter Oberschlitten	Spindle nut top slide	1		0342700115
15	Messingstift	Brass pin	3		0342700115
16	Schwalbenschwanzfuehrung Oberschlitten	Dove tail guidance top slide	1		0342700116
17	Klemmring Oberschlitten	Clamping ring top slide	1		0342700117
18	Skalenring Winkelskala Oberschlitten	Angle scales ring top slide	1		0342700118
19	Innensechskantschraube	Socket head screw	2	GB 70-85 - M6 x 20	
19	Innensechskantschraube	Socket head screw	4	GB 70-85 - M6 x 14	
20	Spindel Oberschlitten	Spindle top slide	1		0342700120
21	Gleitbuchse	Floating bushing, Sliding bearing	2		0342700121
21	Fuehrungsleiste Planschlitten	Guide rail bed slide	1		0342700121
22	Lagerbock Spindel Oberschlitten	Saddle spindle top slide	1		0342700122
23	Skalenring Handrad Oberschlitten	Scales ring handwheel top slide	1		0342700123
24	Fuehrungsscheibe Skalenring	Guide disk scales ring	1		0342700124
25	Hebel Handrad Oberschlitten	Lever handwheel top slide	1		0342700125
26	Handgriff Handrad	Handle handwheel	1		0342700126
27	Befestigungsschraube Griff Handrad	Fixing bolt for handle handwheel	1		0342700127
28	Feder	Spring	1		0342700128
28	Feder Wahlschalter	Spring rotary switch	1		0342700128
29	Stahlkugel	Steel ball	1	5 mm	0342700129
30	Scheibe	Disc	1		0342700130
31	Innensechskantschraube	Socket head screw	1	GB 70-85 - M6 x 25	
32	Bügel	Holder	1		0342700132
34	Senkschraube	Countersunk screw	2	ISO 7046-1 - M5 x 8 - 4.8 - H	
35	Welle	Shaft	1		0342700135
36	Späneschutzschild	Splinter shield	1		0342700136
37	Sechskanthülse	Hexagonal case	1		0342700137
38-1	Innensechskantschraube	Socket head screw	1	GB 70-85 - M3 x 8	
38-2	Sechskantmutter	Hexagon nut	1	ISO 4035 - M3	
38	Zahnradkombination	Gear wheel combination	1		0342700138
39	Innensechskantschraube	Socket head screw	2	GB 70-85 - M3 x 6	
40	Oler	Oiler	14	6 mm	0342700140
41	Gewindestift	Threaded pin	1	ISO 4027 - M6 x 8	
42	Innensechskantschraube	Socket head screw	1	GB 70-85 - M8 x 12	
43	Planschlitten	Cross slide	1		0342700143
44	Messingstift	Brass pin	3		0342700144
45	Innensechskantschraube	Socket head screw	3	GB 70-85 - M6 x 30	
46	Sechskantmutter	Hexagon nut	4	ISO 4032 - M6	
47	Stellschraube	Set screw	1		0342700147
48	Andruckleiste Planschlitten	Pressure border cross slide	1		0342700148
49	Spindelmutter Planschlitten	Spindle nut cross slide	1		0342700149
50	Spindel Planschlitten	Spindle cross slide	1		0342700150
52	Schwalbenschwanzfuehrung Planschlitten	Dove tail guidance cross slide	1		0342700152
54	Abstreifer	Cleaner	2		0342700154
55	Halter Abstreifer	Holder for cleaner	2		0342700155
58	Kreuzschlitzschraube	Cross slot flat head screw	8	GB 6560-86 - M4x12	
59	Paßfeder	Key	1	DIN 6885 - A 4 x 4 x 8	
61	Innensechskantschraube	Socket head screw	1	GB 70-85 - M5 x 10	
62	Lagerbock Spindel Planschlitten	Saddle spindle cross slide	1		0342700162
64	Innensechskantschraube	Socket head screw	2	GB 70-85 - M8 x 20	
65	Skalenring Handrad Planschlitten	Scales ring handwheel cross slide	1		0342700165
66	Handrad Planschlitten	Handwheel cross slide	1		0342700166

TU2807_TU2807V_parts.fm

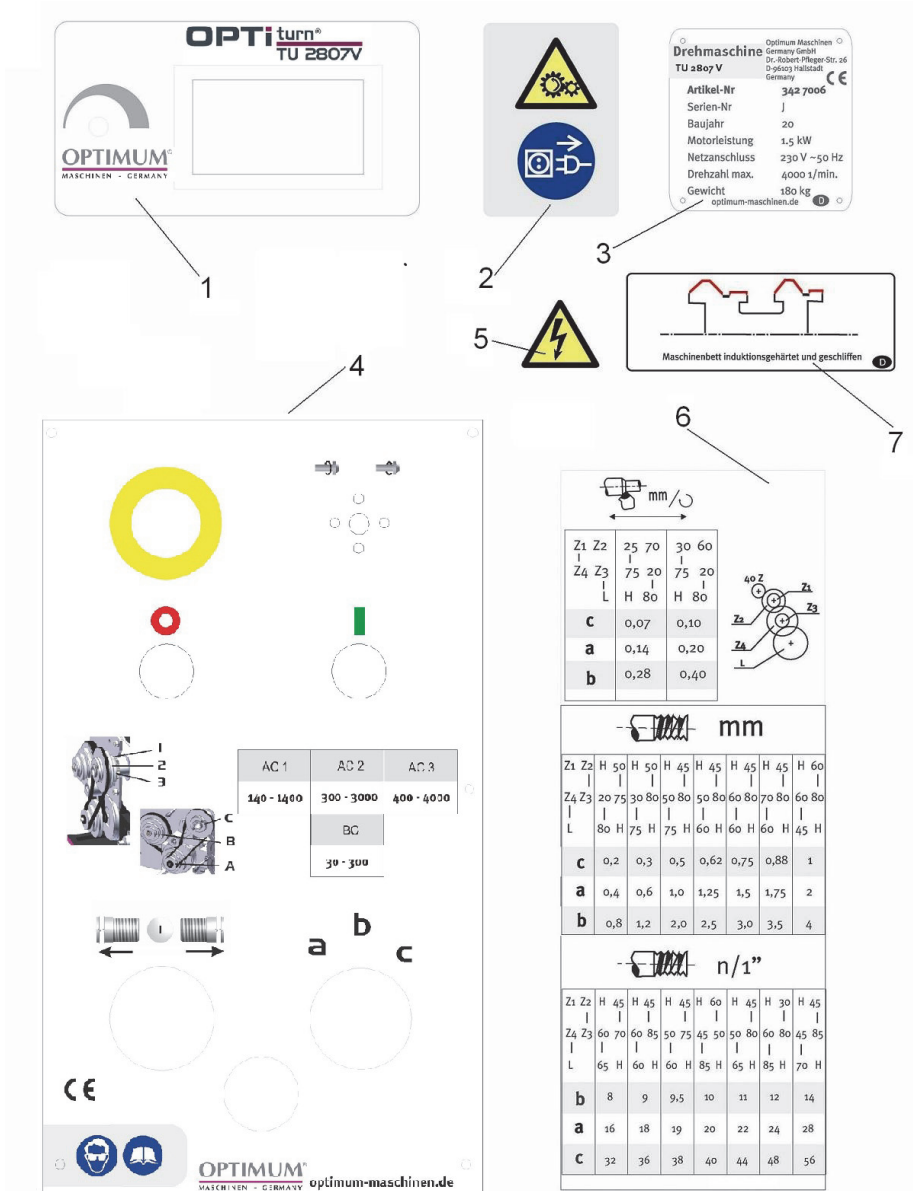
Ersatzteilliste - Spare parts list - TU2807 TU2807V					
Pos.	Bezeichnung	Description	Menge Qty.	Grösse Size	Artikelnummer Item no.
68	Buchse	Socket	1		0342700168
69	Axial-Rillenkugellager	Axially grooved ball bearing	2	51101	04051101
71	Schlosskasten	Apron	1		0342700171
72	Handrad Bettschlitten	Handwheel bed slide	1		0342700172
73	Griff Handrad Bettschlitten	Handle handwheel bed slide	1		0342700173
74	Befestigungsschraube Griff Handrad	Fixing bolt handle handwheel	1		0342700174
76	Sicherungsring	Circlip	1	DIN 471 - 15 x 1	
77	Lagerbock	Saddle	1		0342700177
78	Innensechskantschraube	Socket head screw	5	GB 70-85 - M5 x 25	
79	Gegenlager	Back support	1		0342700179
80	verzahnte Welle	toothed shaft	1		0342700180
81	Paßfeder	Key	1	DIN 6885 - A 3 x 3 x 10	
82	Gewindestift	Threaded pin	1	ISO 4028 - M6 x 16	
83	Scheibe	Washer	1	ISO 7090 - 8 - 140 HV	
84	selbstsichernde Mutter	selflocking nut	1	DIN 6924 - M8	
85	Innensechskantschraube	Socket head screw	2	GB 70-85 - M12 x 35	
86	Skalenring Handrad Bettschlitten	Scales ring handwheel bed slide	1		0342700186
87	Fuehrungsscheibe Skalenring	Guide disk scales ring	1		0342700187
88	Spannstift	Spring pin	1	ISO 8752 - 6 x 45 A	
89	Scheibe Einrueckhebel Vorschub	Disc for lever longitudinal feed	1		0342700189
90	Bewegungsscheibe Schlossmutter	Movement disk	1		0342700190
91	Zylinderstift	Cylindrical pin	2	ISO 2338 - 6 h8 x 12	
92	Schlossmutter	Lock nut	1		0342700192
93	Fuehrungsschiene Schlossmutter	Guide rail lock nut	2		0342700193
94	Innensechskantschraube	Socket head screw	4	GB 70-85 - M6 x 16	
95	Stellschraube	Set screw	1		0342700195
96	Sechskantmutter	Hexagon nut	1	ISO 4032 - M5	
97	Stahlkugel	Steel ball	1		0342700197
98	Feder	Spring	1		0342700198
99	Gewindestift	Threaded pin	1	ISO 4026 - M6 x 6	
105	Spannstift	Spring pin	1	ISO 8752 - 4 x 24 A	
109	Nutenschraube	Slot screw	2		03427001109
110	Sechskantmutter	Hexagon nut	2	ISO 4032 - M10	
117	Innensechskantschraube	Socket head screw	3	GB 70-85 - M5 x 16	
118	Innensechskantschraube	Socket head screw	5	GB 70-85 - M8 x 30	
121	Klemmstück Bettschlittenfuehrung	Shim lathe slide guidance	1		03427001121
122	Bettschlittenfuehrung	bed slide guidance	1		03427001122
124	Lagerbuchse	Bush	1		03427001124
125	Innensechskantschraube	Socket head screw	2	GB 70-85 - M8 x 40	
126	Halter V Abstreifer	Holder fo V cleaner	2		03427001126
127	V Abstreifer	V cleaner	2		03427001127
128	Innensechskantschraube	Socket head screw	2	GB 70-85 - M3 x 6	
129	Rastblech Einrueckhebel Vorschub	Rest sheet metal engaging lever feed motion	1		03427001129
134	Griff Einrueckhebel	Handle engaging lever	1		03427001134
135	Sprengring	Circlip	1	DIN 7993 - A 7	
136	Welle Einrueckhebel	Shaft engaging lever	1		03427001136
137	Feder	Spring	1		03427001137
138	Zylinderschraube mit Schlitz	Cheese head screw with slot	1	ISO 1207 - M5 x 8	
139	Federblech	Spring plate	1		03427001139
142	Zentrierstueck	Piece of centering	3		03427001142
143	Gewindestift	Threaded pin	3	ISO 4026 - M6 x 10	
144	Niet	Rivet	2	DIN 7337 - A2.4 x 6	
145	Markierung	Marking	1		03427001145
146	Scheibe	Washer	2	DIN 125 - A 6.4	
147	Spannstift	Spring pin	1	ISO 8752 - 3 x 16 A	
206	Motorkeilriemenscheibe	Motor V-belt pulley	1	~50Hz	03427001206
	Motorkeilriemenscheibe	Motor V-belt pulley	1	~60Hz	0342700120660Hz
207	Paßfeder	Key	1	DIN 6885 - A 6 x 6 x 45	
208	Innensechskantschraube	Socket head screw	1	GB 70-85 - M6 x 25	
228	Sechskantmutter	Hexagon nut	4	GB 6170-86 - M8	
229-2	Abstandshalter unten	Spacer down	2		034270012292
229-1	Abstandshalter oben	Spacer above	2		034270012291
230	Scheibe	Washer	10	DIN 125 - A 8.4	
231	Motor 230V	Motor 230V	1	230V	0342806
231	Motor 400V	Motor 400V	1	400V	0342801
235	Maschinenbett	Lathe bed	1		03427001235
236	Zahnstange	Rack	2		03427001236

Ersatzteilliste - Spare parts list - TU2807 | TU2807V

Pos.	Bezeichnung	Description	Menge Qty.	Grösse Size	Artikelnummer Item no.
237	Innensechskantschraube	Socket head screw	6	GB 70-85 - M6 x 16	
238	Leitspindel	Lead screw	1	TR 20 x 3	03427001238
239	Verbindungsstueck	Connecting piece	1		03427001239
240	Innensechskantschraube	Socket head screw	3	GB 70-85 - M8 x 25	
242	Lagerbock	Saddle	1		03427001242
245	Nutmutter	Groove nut	2	DIN 1804 - M12	
246	Scheibe	Washer	1	DIN 125 - A 13	
247	Scheibe	Washer	10	DIN 125 - A 8.4	
249	Innensechskantschraube	Socket head screw	3	GB 70-85 - M8 x 25	
251	Innensechskantschraube	Socket head screw	2	GB 70-85 - M8 x 35	
257	Gewindestift Drehfutterflansch	Threaded pin jaw chuck flange	3		03427001257
258	Scheibe	Washer	6	DIN 125 - A 10.5	
259	Innensechskantschraube	Socket head screw	3	GB 70-85 - M8 x 20	
260	Futterflansch	chuck flange	1		03425001260
261	Dreibackenfutter	Three jaw chuck	1	125 mm	03425001261
262	Drehfutterschlüssel	Key for 3 - jaw chuck	1	10 mm	03425001262
263	Schaltergehäuse	Switch housing	1		03427001263
264-1	Schalterkombination 230V	Switch combination 230V	1		0342151
264-1	Schalterkombination 400V	Switch combination 400V	1		0342152
264-1	Schalterkombination 230V	Switch combination 230V	1		03421512008
264-1	Schalterkombination 400V	Switch combination 400V	1		03421522008
265	Flachkopfschraube mit Kreuzschlitz	Cheese head screw	2	ISO 7045 - M4 x 16 - 4.8 - H	
266	Innensechskantschraube	Socket head screw	4	GB 70-85 - M3 x 8	
267	Sichtfenster Drehfutterschutz	Sight jaw ckuck protection	1		03427001267
268	Spannstift	Spring pin	1	GB 879-86 - 5 x 18	
269	Rahmen Drehfutterschutz	Frame jaw ckuck protection	1		03427001269
271	Sechskantmutter	Hexagon nut	4	ISO 4032 - M3	
272	Welle	Shaft	1		03427001272
273	Flansch	Flange	1		03427001273
274	Positionsschalter Drehfutterschutz	Position switch jaw ckuck protection	1		03425001274
275	Scheibe	Washer	8	DIN 125 - A 6.4	
276	Innensechskantschraube	Socket head screw	8	GB 70-85 - M6 x 10	
277	Zugentlastung Anschlusskabel	Strain relief connection cable	1	PG 19	03425001277
278	Stiftschraube	Threaded pin	1	DIN 915 M5 x 12	
279	Deckel Schaltergehäuse	Cover switch housing	1		03427001279
280	Gewindestift	Threaded pin	1	DIN 915 - M5 x 12	
282	Sechskantmutter	Hexagon nut	2	ISO 4032 - M4	
295	Axial Rillenkugellager	Axially grooved ball bearing	2	51102	04051102
297	Messing Abscherstift	Brass shear pin	1		03427001297
298	Zylinderstift	Cylindrical pin	1	ISO 2338 - 5 m6 x 22	
301	Sicherungsring	Circlip	2	DIN 471 - 18 x 1,2	
302	Zahnrad	Gear wheel	1	24 Z m1.25 15 mm	03427001302
304	Welle	Shaft	1		03427001304
305	Zahnrad	Gear wheel	1		03427001305
305-1	Zahnrad	Gear wheel	1		034270013051
305-2	Sicherungsring	Retaining ring	1	DIN 471/16-1	
310	Gewindestift	Threaded pin	1	ISO 4027 - M6 x 10	
311	Gehäuse Vorschubgetriebe	Housing feed gear	1		03427001311
312	Ölverschlussschraube	Oil plug	2		03427001312
314	Buchse	Socket	1		03427001312
315	Gewindestift	Threaded pin	1	ISO 4028 - M6 x 16	
316	Flansch	Flange	1		03427001316
319	Eingangswelle	Entrance shaft	1		03427001319
320	Gleitlager	Sliding bearing	1		03427001320
321	Zahnrad	Gear wheel	1	32 Z m 1.25 6 mm	03427001321
324	verzahnte Welle	toothed shaft	1	16 Z m1.25	03427001324
325	Paßfeder	Key	2		03427001325
326	Sicherungsring	Circlip	2	DIN 471 - 15 x 1	
327	Zahnrad	Gear wheel	1	24 Z m1.25 6 mm	03427001327
328	Rillenkugellager	Grooved ball bearing	2	6202	0406202.2R
329	Flansch	Flange	1		03427001329
330	Innensechskantschraube	Socket head screw	6	GB 70-85 - M5 x 10	
331	Deckel Vorschubgetriebe	Cover feed gear	1		03427001331
332	Innensechskantschraube	Socket head screw	5	GB 70-85 - M6 x 16	
335	Wahlschalter	Rotary switch	2		03427001335
343	Zylinderstift	Cylindrical pin	1	ISO 2338 - 3 h8 x 14	
343	Zylinderstift	Cylindrical pin	1	ISO 2338 - 3 h8 x 14	
344	Mitnehmerhuelse	Case	1		03427001344
345	Scheibe	Disc	1		03427001345

TU2807_TU2807V_parts.fm

Ersatzteilliste - Spare parts list - TU2807 TU2807V					
Pos.	Bezeichnung	Description	Menge Qty.	Grösse Size	Artikelnummer Item no.
346	Rueckwanddeckel	Backwall cover	1		03427001346
347	Senkschraube mit Kreuzschlitz H	Countersunk screw	10	GB 819-85 - M5x8	
348	O-Ring	O-ring	2	DIN 3771 - 15 x 1.8	
349	Buchse rechts	Socket right	1		03427001349
350	Gleitlager Zwischenwelle	Sliding bearing intermediate shaft	1		03427001350
354	Innensechskantschraube	Socket head screw	4	GB 70-85 - M6 x 50	
360	Oelschauglas	Oil sight glass	1	25 mm	03427001360
361	O-Ring	O-ring	1	DIN 3771 20x2,65	
402	Scheibe	Washer	6	DIN 125 - A 10.5	
403	Stiftschraube	Threaded pin	2	GB 897-88 - A M10x120	
404	Sechskantmutter	Hexagon nut	10	GB 6170-86 - M10	
405	Mutter Schutzabdeckung		1		03425001405
406	Spindel	Spindle	1		03427001406
407	Paßfeder	Key	1	DIN 6885 - A 8 x 7 x 40	
408	Lagerabdeckung vorne	Bearing cover in front	1		03427001408
414	Kegelrollenlager	Taper roller bearing	2	32009	04032009
415	Lagerabdeckung hinten	Bearing cover in in the back	1		03427001415
416	Distanzhülse	Spacer	1		03427001416
417	Zahnrad	Toothed wheel	1		03427001417
419	Keilriemen lang	V - belt long	1	10 x 850	0392850
420	Spindelkeilriemenscheibe	Spindle V-belt pulley	1	~50Hz	03427001420
	Spindelkeilriemenscheibe	Spindle V-belt pulley	1	~60Hz	0342700142060Hz
421	Innensechskantschraube	Socket head screw	4	GB 70-85 - M5 x 10	
422	Lagerring	Bearing ring	2		03427001422
423	Wellenmutter	Shaft nut	1		03427001423
424	Welle	Shaft	1		03427001424
425	Zahnriemen	Toothed belt	1	240L075	0392800
427	Zahnriemenscheibe	Toothed belt disk	1	~50Hz	03427001427
	Zahnriemenscheibe	Toothed belt disk	1	~60Hz	0342700142760Hz
428	Sicherungsring	Circlip	2	DIN 471 - 12 x 1	
430-1	Bundscheibe hinten	Flanged washer in front	1		034270014301
430-2	Bundscheibe vorne	Flanged washer in the back	1		034270014302
430	Motorzahnriemenscheibe	Motor V-belt pulley	1		03427001430
433	Scheibe	Washer	1	DIN 125 - A 8,4	
434	Innensechskantschraube	Socket head screw	1	GB 70-85 - M8 x 35	
436	Exzentrerscheibe Spannrolle	Eccentric disk idler	1		03427001436
437	Welle Spannrolle	Shaft for idler	1		03427001437
438	Rillenkugellager	Grooved ball bearing	2	6001RZ	0406001.2R
439	Spannrolle	Idler	1		03427001439
440	Sicherungsring	Circlip	3	DIN 472 - 28 x 1.2	
441	Schutzabdeckung Spindelstock	Protection cover headstock	1		03427001441
441-3	Faldeckel	Drop cover	1		034270014413
441-2	Zylinderschraube mit Schlitz	Cheese head screw with slot	1	ISO 7045 - M5 x 10	
441-1	Scheibe	Washer	1	DIN 125 - A 5.3	
443	Scheibe	Washer	1		03427001443
453	Sechskantmutter	Hexagon nut	1	ISO 4032 - M10	
454	Rillenkugellager	Grooved ball bearing	2	6001_Z	0406001.2R
455	Scheibe	Washer	1	DIN 125 - A 10.5	
470	Grundplatte	Baseplate	1		03427001470
472	Scheibe	Washer	3	DIN 125 - A 8.4	
473	Innensechskantschraube	Socket head screw	2	GB 70-85 - M8 x 20	
502	Innensechskantschraube	Socket head screw	1	DIN 912 M8 x 35	
503	Wechselradschiene	Change gear train	1		03425001503
504	Lagerbock Wechselradschiene	Saddle change gear train	1		03427001504
505	Innensechskantschraube	Socket head screw	3	DIN 912 M5 x 10	
506	Wechselrad, t=9 mm, Di=14 mm	Change gear	1	85 Zähne, Modul 1,5	03425001506
507	Wechselrad, t=9 mm, Di=14 mm	Change gear	1	80 Zähne, Modul 1,5	03425001507
508	Wechselrad, t=9 mm, Di=14 mm	Change gear	1	75 Zähne, Modul 1,5	03425001508
509	Wechselrad, t=9 mm, Di=14 mm	Change gear	1	65 Zähne, Modul 1,5	03425001509
510	Wechselrad, t=9 mm, Di=14 mm	Change gear	1	60 Zähne, Modul 1,5	03425001510
511	Wechselrad, t=9 mm, Di=14 mm	Change gear	2	50 Zähne, Modul 1,5	03425001511
512	Wechselrad, t=9 mm, Di=14 mm	Change gear	1	70 Zähne, Modul 1,5	03425001512
514	Wechselrad, t=9 mm, Di=14 mm	Change gear	1	45 Zähne, Modul 1,5	03425001514
515	Wechselrad, t=9 mm, Di=14 mm	Change gear	1	30 Zähne, Modul 1,5	03425001515
516	Wechselrad, t=9 mm, Di=14 mm	Change gear	1	20 Zähne, Modul 1,5	03425001516
517	Nutenstein Wechselradschiene	Groove stone change gear	2	M5	03425001517
518	Distanzscheibe	Shim	1	1,5 mm	03425001518
519	Distanzscheibe	Shim	1	3 mm	03425001519
520	Verbindungshülse Wechselräder	Connecting case of change gears	2		03425001520

Ersatzteilliste - Spare parts list - TU2807 | TU2807V

Pos.	Bezeichnung	Description	Menge Qty.	Grösse Size	Artikelnummer Item no.
521	Klemschraube Wechselrad	Clamping screw change gear	2		03425001521
522	Befestigungsring	Attachment ring	1		03425001522
523	Hülse Wechselrad	Case change gear	1		03425001523
524	Scheibe	Washer	1		03425001524
525	Innensechskantschraube	Socket head screw	1	DIN 912 M6 x 10	
601	Spritzwand D280x700G/TU2807	Splash wall D280x700G/TU2807	1		03427001601
601	Spritzwand D280x700 DC Vario/TU2807V	Splash wall D280x700 DC Vario/TU2807V	1		03427006601
602	Kreuzschlitzschraube	Cross slot flat head screw	6	GB 6560-86 - M5x10	
603	Abdeckblech	Cover plate	1		03427001603
605	Innensechskantschraube	Socket head screw	10	GB 70-85 - M3 x 8	
605	Innensechskantschraube	Socket head screw	10	GB 70-85 - M3 x 5	
607	Gewindeschneidtablette	Thread cutting table	1		03427001607
611	Spänewanne D280x700G/TU2807	Chip pan D280x700 G/TU2807	1		03427001611
611	Spänewanne D280x700 DC Vario/TU2807V	Chip pan D280x700 DC Vario/TU2807V	1		03427006611
612	Gummiablage	Rubber	1		03427001612
615	Schaltkasten für Vario	Switch box for Vario type	1		03425001615
901	Unterbau Reitstock	Base plate tailstock	1		03427001901
902	Innensechskantschraube	Socket head screw	2	GB 70-85 - M8 x 40	
903	Reitstock Oberteil	Tailstock upper section	1		03427001903
904	Verstellrichtung	Adjustment device	1		03427001904
905	Gewindestift	Threaded pin	1	ISO 4028 - M6 x 16	
906	Klemmteil Pinole	Clamping piece spindle sleeve	2		03427001906
907	Klemmteil Pinole	Clamping piece spindle sleeve	1		03427001907
908	Pinole	Spindle sleeve	1		03427001908
909	Spindel	Spindle	1		03427001909
910	Zentrierstück Pinole	Piece of centering of spindle sleeve	1		03427001910
911	Innensechskantschraube	Socket head screw	2	GB 70-85 - M5 x 16	
912	Skalenring	Scales ring	1		03427001912
913	Zentrierring	Centering ring	1		03427001913
914	Kugel	Steel ball	1	D = 5 mm	03427001914
915	Spiralfeder	Spiral spring	1		03427001915
916	Paßfeder	Key	1	DIN 6885 - A 3 x 3 x 10	
917	Innensechskantschraube	Socket head screw	3	ISO 4026 - M6 x 10	
918	Messingklemmstück	Brass clamping piece	3		03427001918
919	Handrad	Handwheel	1		03427001919
920	Sechskantmutter	Hexagon nut	1	DIN EN 24 032 M8	
921	Unterlegscheibe	Disc	1		03427001921
922	Handgriff Handrad	Handle handwheel	1		03427001922
923	Befestigungsschraube Griff Handrad	Fixing bolt for handle handwheel	1		03427001923
925	Klemmmutter	Clamping nut	1		03427001925
926	Unterlegscheibe	Disc	1	D = 8	03427001926
927	Griff Spannhebel	Handle clamping lever	1		03427001927
928	Spannhebel	Clamping lever	1		03427001928
929	Scheibe	Innensechskantschraube	1		03427001929
930	Spannstift	Spring pin	1	ISO 8752 - 4 x 28 A	
931	Fuehrungsbuchse	Guide bush	1		03427001931
932	Spannstift	Spring pin	1	ISO 8752 - 4 x 24 A	
933	Gewindestange	Threaded rod	1		03427001933
934	Spannschraube	Tightening screw	1		03427001934
935	Feder	Spring	1		03427001935
936	Klemmplatte	Clamping plate	1		03427001936
937	Sechskantmutter	Hexagon nut	1	ISO 4035 - M12	
938	Scheibe	Washer	2	DIN 125-1 A 13	
939	Zentrierstueck Pinole	Piece of centering of spindle sleeve	1		03427001939
940	Skala	Skale	1		03427001940
941	Exzenter	Eccentric cam	1		03427001941
942	Gewindestift	Threaded pin	2	ISO 4028 - M5 x 12	
945	Spannhebel	Clamping lever	1		03427001945
946	Markierung	Marking	1		03427001946
948	Grundplatte	Base plate	1		03427001948
949	Reitstock Oberteil	Tailstock upper section	1		03427001949
950	Niet	Rivet	4	DIN 7337 - A2.4 x 6	
951	NOT-Halt Schalter	Emergency stop button	1		03427001951
952	Trafo	Transformer	1		03427001952

TU2807_TU2807V_parts.fm

Ersatzteilliste - Spare parts list - TU2807 | TU2807V

Pos.	Bezeichnung	Description	Menge Qty.	Grösse Size	Artikelnummer Item no.
953	Schalter R-und L-Lauf	Change over switch	1		03427001953
954	Positionsschalter Spindelstockabdeckung	Position switch headstock protection	1		03427001954
955	Kondensator (230V)	Capacitor (230V)	1	150µF	03427001955
956	Kondensator (230V)	Capacitor (230V)	1	30µF	03427001956
C1	Frequenzumrichter	Frequency converter	1	Lenze 8200 vector	0313125
C2	Funktionsmodul	Functionmodule	1		0313105
P3	Potentiometer	Potentiometer	1	1KOhm	0313199
946	Skala	Scale	1		
947	Lagerbock	Saddle	1		
948	Grundplatte Reitstock	Base plate tailstock	1		
949	Reitstock Oberteil	Tailstock upper section	1		
950	Klemmteil Pinole	Clamping part collar	1		
951	Innensechskantschraube	Socket head screw	4	GB 70-85 - M5 x 14	
952	Kopf Spannhebel	Head clamping lever	1		
953	Not-Aus-Schalter	Emergency stop button	1		0460049
954	Trafo	Transformer	1		
955	Schalter R-und L-Lauf	Change over switch	1		0460009
956	Positionsschalter Spindelstockabdeckung	Position switch headstock protection	1		0460016
957-1	Abdeckung Kondensator	Cover capacitor	1		
957-2	Abdeckung Kondensator	Cover capacitor	1		
958-1	Kondensator (230V)	Capacitor (230V)	1	25µF	
958-2	Kondensator (230V)	Capacitor (230V)	1	150µF	
C1	Frequenzumrichter	Frequency converter	1	Lenze 8200 vector	0313125
C2	Funktionsmodul	Functionmodule	1		0313105
P3	Potentiometer	Potentiometer	1	1K Ohm	0313199

2 Schaltpläne - Wiring diagrams

2.1 Schaltplan - Wiring diagram TU 2506 - 230V

TU2506_TU2506V_TU2807_TU2807V_wiring_diagrams.fm



Abb.2-1: Schaltplan - Wiring diagram

2.3 Schaltplan - Wiring diagram TU 2506 V / TU 2807 V

TU2506_TU2506V_TU2807_TU2807V_wiring_diagrams.fm

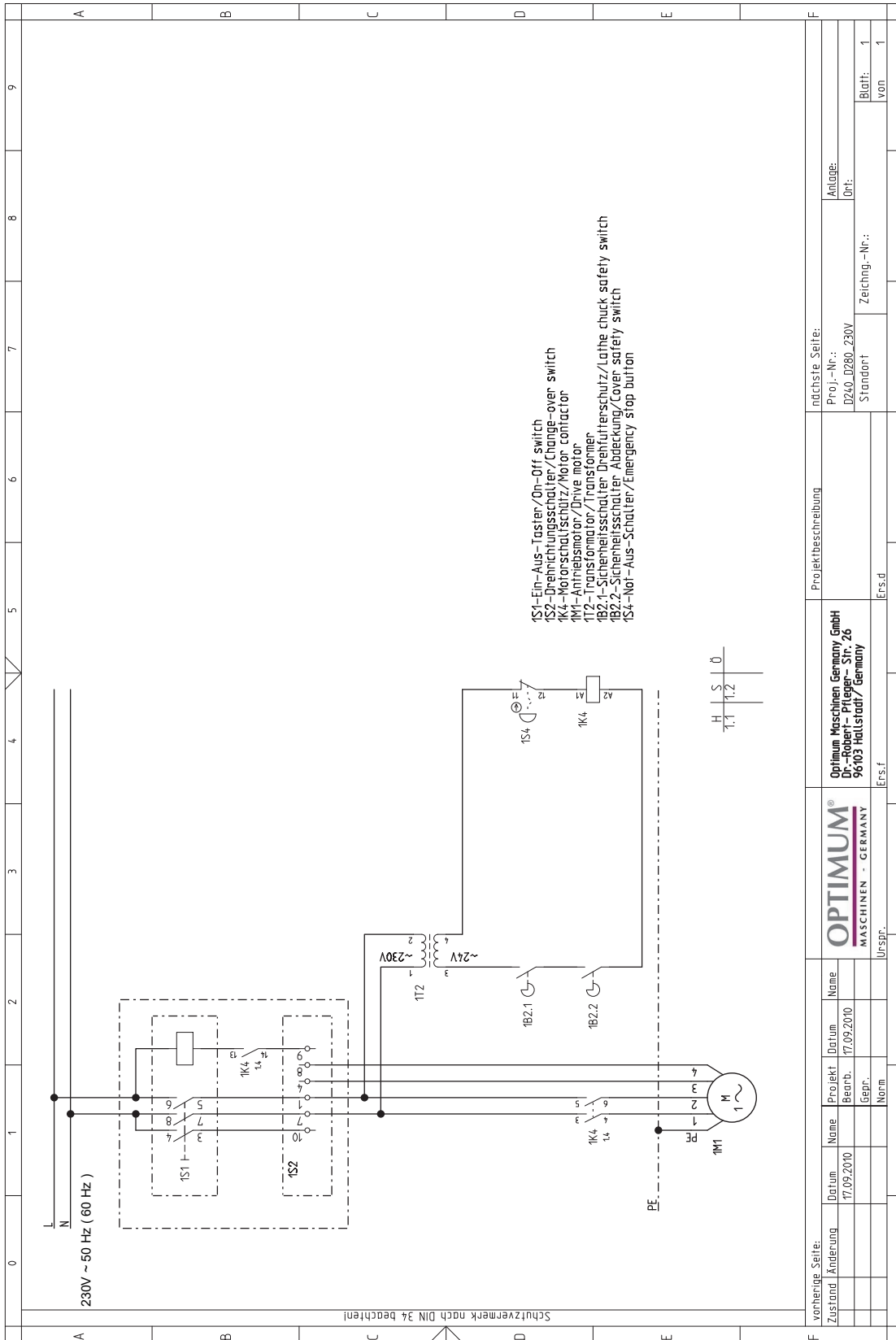

Abb.2-3: Schaltplan - Wiring diagram

Schmierstoffe Lubricant Lubrifiant	Viskosität Viscosity Viscosité ISO VG DIN 51519 mm ² /s (cSt)	Kennzeichnun g nach DIN 51502							
Getriebeöl Gear oil Huile de réducteur	VG 680	CLP 680	Aral Degol BG 680	BP Energol GR-XP 680	SPARTAN EP 680	Kiüberoil GEM 1-680	Mobilgear 636	Shell Omala 680	Meropa 680
	VG 460	CLP 460	Aral Degol BG 460	BP Energol GR-XP 460	SPARTAN EP 460	Kiüberoil GEM 1-460	Mobilgear 634	Shell Omala 460	Meropa 460
	VG 320	CLP 320	Aral Degol BG 320	BP Energol GR-XP 320	SPARTAN EP 320	Kiüberoil GEM 1-320	Mobilgear 632	Shell Omala 320	Meropa 320
	VG 220	CLP 220	Aral Degol BG 220	BP Energol GR-XP 220	SPARTAN EP 220	Kiüberoil GEM 1-220	Mobilgear 630	Shell Omala 220	Meropa 220
	VG 150	CLP 150	Aral Degol BG 150	BP Energol GR-XP 150	SPARTAN EP 150	Kiüberoil GEM 1-150	Mobilgear 629	Shell Omala 150	Meropa 150
	VG 100	CLP 100	Aral Degol BG 100	BP Energol GR-XP 100	SPARTAN EP 100	Kiüberoil GEM 1-100	Mobilgear 627	Shell Omala 100	Meropa 100
	VG 68	CLP 68	Aral Degol BG 68	BP Energol GR-XP 68	SPARTAN EP 68	Kiüberoil GEM 1-68	Mobilgear 626	Shell Omala 68	Meropa 68
	VG 46	CLP 46	Aral Degol BG 46	BP Bartran 46	NUTO H 46 (HLP 46)	Kiüberoil GEM 1-46	Mobil DTE 25	Shell Tellus S 46	Anubia EP 46
	VG 32	CLP 32	Aral Degol BG 32	BP Bartran 32	NUTO H 32 (HLP 32)	Kiübersynth GEM 4-32 N	Mobil DTE 24	Shell Tellus S 32	Anubia EP 32
	VG 32	CLP 32	CLP 32	Aral Vitam GF 32	BP Energol HLP HM 32	LAMORA HLP 32	Mobil Nuto HLP 32	Shell Tellus S2 M 32	Rando HD HLP 32
VG 46	CLP 46	CLP 46	Aral Vitam GF 46	BP Energol HLP HM 46	LAMORA HLP 46	Mobil Nuto HLP 46	Shell Tellus S2 M 46	Rando HD HLP 46	
Getriebefett Gear grease Graisse de réducteur		G 00 H-20	Aral FDP 00 (Na-verseift) Aralub MFL 00 (Li-verseift)	BP Energ grease PR-EP 00	FIBRAX EP 370 (Na-verseift)	MICROLUB E GB 00	Mobilux EP 004	Shell Alvania GL 00 (Li-verseift)	Marfak 00

oil-compare-list.fm

Spezialfette, wasserabweisend Special greases, water resistant Graisses spéciales, déperlant		Aral Aralub	Energrease PR 9143		ALTEMP Q NB 50 Klüberpaste ME 31-52	Mobilux EP 0 Mobil Greaserex 47		
Wälzlagerfett Bearing grease Graisse de roulement	K 3 K-20 (Li+verseift)	Aralub HL 3	BP Energrease LS 3	BEACON 3	CENTOPLE X 3	Mobilux 3	Shell Alvania R 3 Alvania G 3	Multifak Premium 3
Öle für Gleitbahnen Oils for slideways Huiles pour glissières	VG 68	Aral Deganit BWX 68	BP Maccurat D68	ESSO Febis K68	LAMORA D 68	Mobil Vactra Oil No.2	Shell Tonna S2 M 68	Way lubricant X 68
Öle für Hochfrequenzspindeln Oils for Built-in spindles Huiles pour broches à haute vitesse	VG 68	Deol BG 68	Emergol HLP-D68	Spartan EP 68		Drucköl KLP 68-C	Shell Omala 68	
Fett für Zentralschmierung (Fließfett) Grease for central lubrication Graisse pour lubrification centrale	NLGI Klasse 000 NLGI class 000	ARALUB BAB 000	Grease EP 000	Shell Gadus S4 V45AC	CENTOPLE X GLP 500	Mobilux EP 023		Multifak 264 EP 000
Fett für Hochfrequenzspindeln Grease for Built-in spindles Graisse pour broches à haute vitesse	<p>METAFLUX-Fett-Paste (Grease paste) Nr. 70-8508 METAFLUX-Moly-Spray Nr. 70-82</p> <p>Techno Service GmbH ; Detmolder Strasse 515 ; D-33605 Bielefeld ; (++49) 0521- 924440 ; www.metaflux-ts.de</p>							
Kühlschmiermittel Cooling lubricants Lubrifiants de refroidissement	Schneidöl Aquacut C1, 10 L Gebinde, Artikel Nr. 3530030 Cutting oil Aquacut C1, 10 L container, art.no. 3530030	Aral Emusol	BP Sevora	Esso Kutwell		Mobilcut	Shell Adrana	Chevron Soluble Oil B

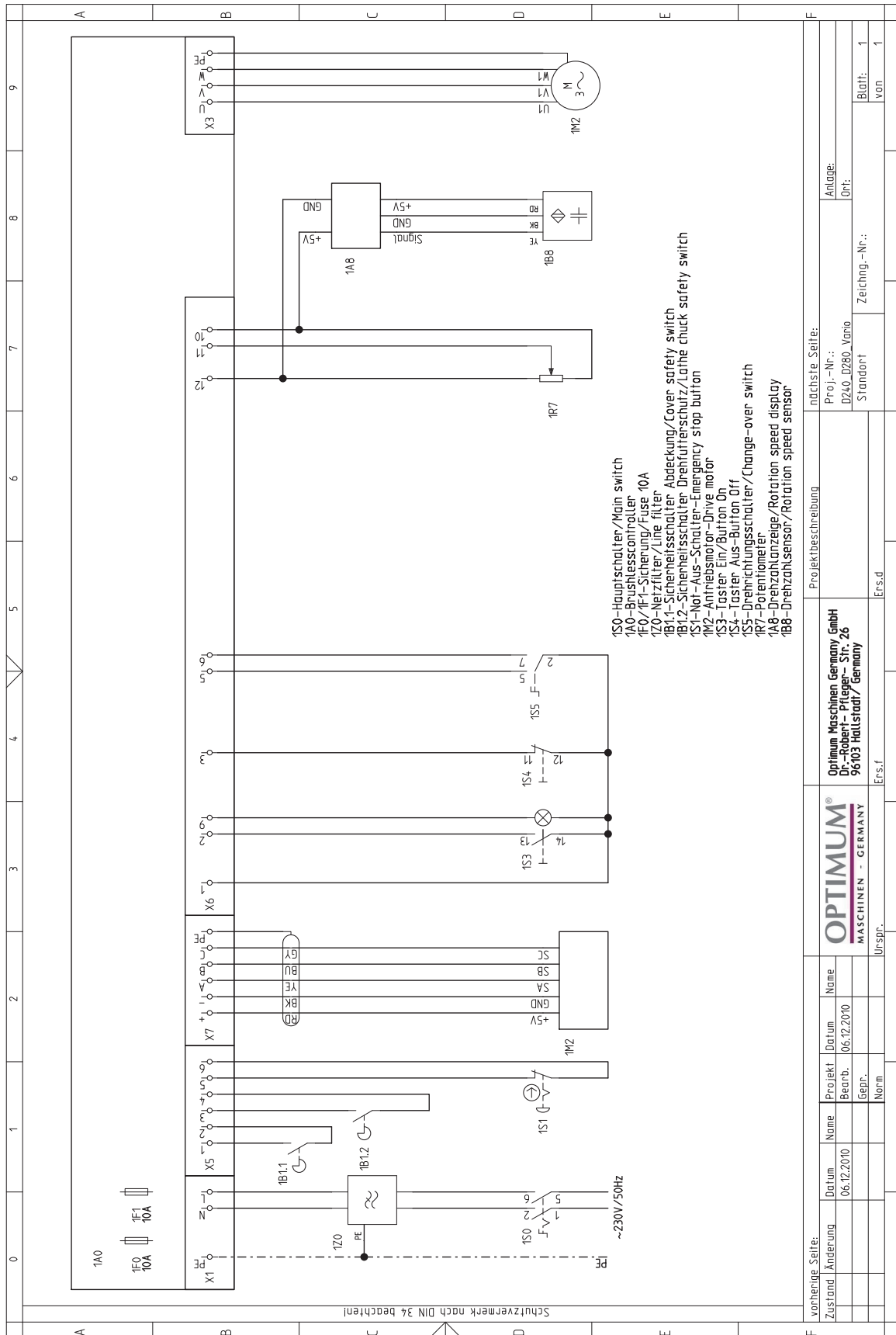